

1991

## Cognitive Load Theory and the Format of Instruction

Paul Chandler

*University of New South Wales*, [chandler@uow.edu.au](mailto:chandler@uow.edu.au)

John Sweller

*University of New South Wales*

Follow this and additional works at: <https://ro.uow.edu.au/edupapers>



Part of the [Education Commons](#)

---

### Recommended Citation

Chandler, Paul and Sweller, John: Cognitive Load Theory and the Format of Instruction, *Cognition and Instruction*: 8(4) 1991, 293-332.  
<https://ro.uow.edu.au/edupapers/128>

## Cognitive Load Theory and the Format of Instruction

Paul Chandler and John Sweller  
*University of New South Wales*

Cognitive load theory suggests that effective instructional material facilitates learning by directing cognitive resources toward activities that are relevant to learning rather than toward preliminaries to learning. One example of ineffective instruction occurs if learners unnecessarily are required to mentally integrate disparate sources of mutually referring information such as separate text and diagrams. Such split-source information may generate a heavy cognitive load, because material must be mentally integrated before learning can commence. This article reports findings from six experiments testing the consequences of split-source and integrated information using electrical engineering and biology instructional materials. Experiment 1 was designed to compare conventional instructions with integrated instructions over a period of several months in an industrial training setting. The materials chosen were unintelligible without mental integration. Results favored integrated instructions throughout the 3-month study. Experiment 2 was designed to investigate the possible differences between conventional and integrated instructions in areas in which it was not essential for sources of information to be integrated to be understood. The results suggest that integrated instructions were no better than split-source information in such areas. Experiments 3, 4, and 5 indicate that the introduction of seemingly useful but nonessential explanatory material (e.g., a commentary on a diagram) could have deleterious effects even when presented in integrated format. Experiment 6 found that the need for physical integration was restored if the material was organized in such a manner that individual units could not be understood alone. In light of these results and previous findings, suggestions are made for cognitively guided instructional packages.

Over the last decade, there have been considerable interest and debate in areas of cognition and education. Nevertheless, until recently, our knowledge of the cognitive processes involved in understanding instructional material has been somewhat limited. In the last few years, however, cognitive science has progressed to a point where it is becoming obvious that traditional methods of instructional

---

Requests for reprints should be sent to John Sweller, School of Education, University of New South Wales, P.O. Box 1, Kensington, New South Wales, Australia 2033.

design based on visual elegance, common sense, and convenience are inadequate. Recently, new instructional procedures guided by cognitive theory have become available. In this article, we present findings that have implications for the presentation of instructional materials. The experiments reported were generated by cognitive load theory, which is discussed in the next section.

### COGNITIVE LOAD THEORY AND INSTRUCTIONAL PROCESSES

Cognitive load theory (see Sweller, 1988, 1989) is concerned with the manner in which cognitive resources are focused and used during learning and problem solving. Many learning and problem-solving procedures encouraged by instructional formats result in students engaging in cognitive activities far removed from the ostensible goals of the task. The cognitive load generated by these irrelevant activities can impede skill acquisition.

The lack of concordance between the cognitive demands of some tasks and the goals of those tasks first became apparent in studies concerned with relations between learning and problem solving (e.g., see Sweller, Mawer, & Howe, 1982; Sweller, Mawer, & Ward, 1983). Subjects could solve problems, in some cases repeatedly solve problems, and remain oblivious to their essential structure. It was theorized that the search strategies used, although important in attaining problem goals, were ineffective as learning devices. The extraneous cognitive load imposed by the problem-solving strategy interfered with learning.

There are many experiments demonstrating that conventional problem solving can have negative learning consequences. This body of evidence questions the usefulness of solving large numbers of conventional problems (in the areas of mathematics and science, see Cooper & Sweller, 1987; Owen & Sweller, 1985; Sweller & Cooper, 1985; Sweller et al., 1983; Ward & Sweller, 1990).

The use of worked examples is one technique designed to circumvent the interference with learning caused by some forms of problem solving. Sweller and Cooper (1985) and Cooper and Sweller (1987) found that a heavy use of worked examples resulted in more rapid learning than the conventional emphasis on solving a large number of problems. In a longitudinal study, Zhu and Simon (1987) found worked examples to be highly effective. Chi, Bassok, Lewis, Reimann, and Glaser (1989) found more able students were better than less able students at generating detailed explanations of worked examples and had a greater awareness of comprehension failures. These results indicate the importance to learning of an ability to properly process worked examples.

Cognitive load theory has been used to explain why studying worked examples can facilitate learning compared with problem solving (e.g., see Cooper & Sweller, 1987; Sweller, 1988). In essence, searching for suitable problem-solving

operators is cognitively demanding and directs attention away from aspects of the problem important to learning. In contrast, many worked examples are far easier to process than the equivalent problems and direct attention more appropriately. Nevertheless, not all worked examples appropriately direct attention and reduce cognitive load.

Tarmizi and Sweller (1988), using geometry, and Ward and Sweller (1990), using physics, explained how worked examples in some areas could be ineffective. Many worked examples consist of multiple sources of mutually referring information. Diagrams and sets of explanatory statements provide a very common example. Most geometry worked examples consist of a diagram and a set of statements describing relations between entities on the diagram. Little meaning may be extracted from the diagram alone, and the statements may be totally meaningless in isolation. To follow such examples, attention must be focused on mentally integrating the various sources of information, for alone they are unintelligible. Mental integration requires searching for appropriate referents in the diagram or set of statements and understanding that a statement such as "angle ABC" is identical to a particular entity in the diagram. This search process can be expected to have the same consequences as searching for operators to solve a problem. Attention is misdirected, and cognitive resources are devoted to an activity that, although an essential precursor to learning, is itself unrelated to learning. If cognitive effort is devoted to activities other than learning, we might expect interference with learning.

Tarmizi and Sweller (1988) and Ward and Sweller (1990) obtained results in accordance with the cognitive load hypothesis as applied to worked examples. They found that worked examples requiring learners to split their attention between multiple sources of information were no more effective and possibly less effective than problem solving. It was hypothesized that, if such worked examples are reformatted to reduce or eliminate split attention, the reduction in cognitive load due to the reduction in the need to search for relevant referents and mentally integrate them should result in effective worked examples. For example, by physically integrating geometry statements with the diagram, mental integration is no longer necessary, and the cognitive load involved in mental integration should be eliminated and learning enhanced. Many experiments confirmed this suggestion.

In summary, we can hypothesize that presentation techniques frequently result in high levels of extraneous cognitive load that influence the degree to which learning can be facilitated. It follows that information should be presented in ways that do not impose a heavy extraneous cognitive load. Problem solving frequently fails to meet this criterion. Alternatives to conventional problem solving, such as worked examples, are only useful if they also meet this criterion. For this reason, worked examples that require learners to mentally integrate multiple sources of information are ineffective.

USING COGNITIVE LOAD THEORY  
TO DESIGN INITIAL INSTRUCTION

We have argued that a greater than normal use of worked examples is essential to cognitively guided instruction. However, worked examples are only one part of instruction. Normally, they are preceded by introductory explanatory materials. The structure of these introductory materials usually is determined by such variables as visual elegance, convenience, and tradition. The use of multiple sources of mutually referring information is frequent. For example, it is common for diagrams and text to be presented separately. With separate diagrams and text, the information often is unintelligible prior to being mentally integrated.

The same cognitive load principles should apply to initial instruction and to worked examples. Mental integration is likely to be cognitively taxing whether required for a worked example or for initial instruction. Ideal formats for initial instruction should reduce extraneous cognitive load. For this reason, we can hypothesize that all disparate sources of information should be physically integrated where they can save learners from performing unnecessary mental integrations that interfere with learning. Sweller, Chandler, Tierney, and Cooper (1990) tested this hypothesis. Using coordinate geometry and numerical control programming, they found that, if initial explanatory instructions were presented in conventional split-source format, learning was substantially slower than if the same materials were presented using a unified format. Cognitive load theory was used to generate the relevant experiments.

Under what conditions might the physical integration of disparate sources of information not be beneficial? We hypothesize that physical integration is important only where the disparate sources of information are unintelligible unless integrated. The requirement to mentally integrate imposes a heavy cognitive load. For example, the statements associated with a geometry proof are likely to be meaningless unless integrated with the diagram. Nevertheless, multiple sources of information frequently are quite intelligible without being integrated. A source of information may be used as a self-contained unit designed to buttress another unit of information. For example, the contents of a diagram may be repeated in textual form. The diagram and the text may be independently intelligible. The information contained in each may be functionally redundant with mental integration unnecessary. Under these circumstances, there are no theoretical reasons for supposing that physical or mental integration is likely to be beneficial.

The current set of experiments was generated by cognitive load theory. These experiments were designed to test whether the physical integration of split-source introductory materials is beneficial when the individual components are unintelligible in isolation but irrelevant when the individual components can be understood in isolation. It might be noted that the experiments were not designed to test the validity of cognitive load theory. They were designed to test whether the theory could generate findings with direct applications. In this article, our

only concern is whether cognitive load theory can be used to design effective instruction.

Experiments 1 and 2 were conducted in industrial training settings over a 3-month period, using instructional material relevant to electrical apprentices. Experiment 1, using the area of installation testing, was designed to test the hypothesis that integrated instructional materials are superior to conventional, split-source instructional formats where the material must be integrated for understanding. The instructional materials for Experiment 2, based on lighting wiring, were different from Experiment 1 in that the sources of information did not have to be mentally integrated in order to be understood. Experiments 3 and 4 evolved from the findings of Experiment 2. Together, they investigated the possibility that, in some instructional areas, a single source of information is superior to multiple sources of information, in either an integrated or conventional, split-attention format. Experiments 5 and 6 attempted to replicate some of the basic findings of the previous experiments using a totally different area—the process of blood circulation in the human body.

## EXPERIMENT 1

This experiment was designed to compare conventional introductory instructional materials with integrated instructions using elementary electrical engineering. When electrical equipment or new wiring is installed, it must be tested to ensure that the installation procedure has been carried out correctly. This procedure, called *installation testing*, provided materials for the first experiment.

The experiment used detailed instructional booklets and three separate test periods over a 12-week period. It was conducted in the training center of a major Sydney company. Two groups were used. The first received introductory instructional notes on installation testing in a conventional split-source format. The second group was presented with instructional notes in an integrated format. The integrated materials contained virtually identical information to the conventional instructions, with the only difference being the format of the presentation. It was predicted that integrated instructions designed to focus attention appropriately and reduce cognitive load would be superior to conventional instructions.

### Method

**Subjects.** The subjects were 28 first-year trade apprentices from a Sydney, Australia, company. All subjects had completed at least Year 10 of high school and were enrolled in first-year trade courses at various technical colleges. None of the subjects used in the experiment had any prior formal training in electrical areas.

**Materials.** The instructional materials consisted of two sets of introductory instructional notes (conventional and modified) on installation testing. Both sets of notes were designed to introduce apprentices to the equipment used in installation testing and to demonstrate how this equipment could be used for various electrical tests. Specifically, there were notes on megger meters (a meter designed to measure insulation and circuit resistance), multimeters (a meter designed to measure voltage, current, and resistance), conductors in permanent wiring, electrical continuity of earthing systems, and procedures for testing electrical appliances.

The conventional instructional notes, in the form of a 10-page booklet, were very similar to the regular instructions used by the company as part of its electrical training program. The very limited revisions made to the instructions were only in the interest of clarifying minor ambiguities. These notes were in a conventional, split-source format; text and diagrams were presented separately, and sources of related textual information also were presented separately. An example of the instructions from the conventional notes is presented in Figure 1. The modified instructional notes contained the same information but in an integrated format. Mutually referring sources of information were integrated, where possible, into unitary sources of information. An example of the instructions from the modified notes is contained in Figure 2.

The test materials consisted of a test booklet, as well as the equipment for practical tests. The test booklet was divided into four sections covering questions on (a) conductors in permanent wiring, (b) continuity of earthing systems, (c) testing of electrical appliances, and (d) multimeters. The questions for the first three of these required subjects to recall the installation testing procedure for each of the areas. In each of these three areas, the subjects were asked (a) to indicate to what the megger meter should be set to carry out the test, (b) to indicate on diagrams how they would conduct the tests, and (c) to indicate the required results for the tests. The questions relating to the use of the multimeter concerned (a) the function of a multimeter, (b) safety precautions when using the meter, and (c) procedures for using a multimeter. In total, there were 28 questions. All questions were designed to be completely objective and were marked as either correct or incorrect. One mark was allocated for a correct response, and no mark was given for an incorrect response.

There were two practical tests. The first involved testing the safety of an electrical appliance. The materials used for this test were an electric kettle with lead and a megger meter. Four safety tests were required. Each of the four tests involved placing the leads of the megger meter on appropriate parts of the kettle and comparing it with the required regulation reading. For example, to test the earth continuity of the appliance, one lead of the megger needed to be placed on the earth pin while the other lead of the megger meter was on the frame of the kettle. The required reading by regulation for this test is 2 ohms or less. For each of the four safety tests, one mark was allocated for successfully performing

INSULATION RESISTANCE TESTS

a) CONDUCTORS IN PERMANENT WIRING

Test : To test Insulation Resistance from conductors to earth

How conducted : i ) Disconnect appliances and busways during these tests. Make sure main switch is "on" and all fuses are "in". Remove main earth from neutral bar and set meter to read insulation. Connect one lead to earth wire at MEN bar and take first measure by connecting the other lead to the active. Take next measure by connecting the lead to the neutral.  
 ii) If resistance is not high enough in either of the two tests in i) then measure each circuit separately.

Results required : i) At least One Megaohm  
 ii) Same result as i) above

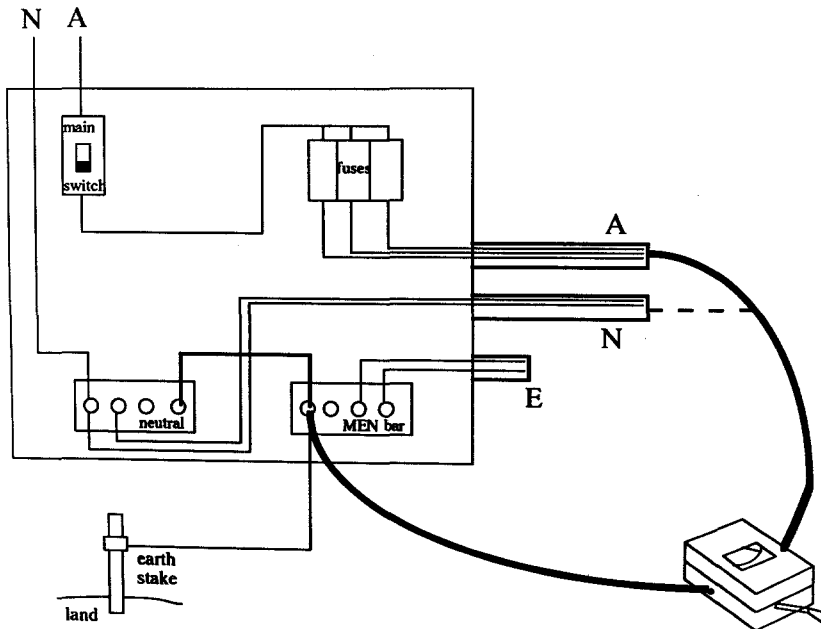

FIGURE 1 Example of the instructional format presented to the conventional group of Experiment 1. A = active, N = neutral, and E = earth. All subjects were aware of these abbreviations prior to the experiment.

the test and one mark was given for successfully recalling the required reading. This gave a total mark out of eight for the first practical test.

The second practical test involved testing the safety of an intermediate light switch. (An intermediate light switch is used in long corridors and hallways. It also is used for the lighting of stairs in multistory buildings.) A megger meter was again required in order to conduct insulation resistance and earth continuity



INSULATION RESISTANCE TESTS

a) CONDUCTORS IN PERMANENT WIRING

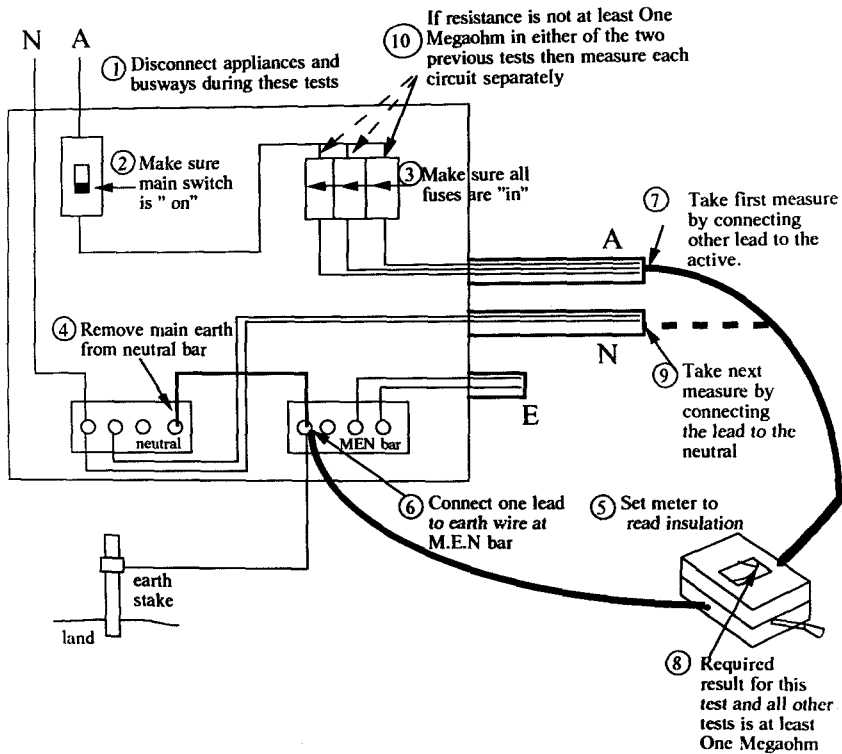

FIGURE 2 Example of the instructional format presented to the modified group of Experiment 1.

tests. Each test involved placing the leads of the megger meter on appropriate parts of the intermediate light switch. The same marking system used in the first practical test was used here. This scheme gave a total mark out of four for the second practical test.

*Procedure.* The experiment was conducted as part of the normal training program of the company. The company used a "multiskilling" training system in which apprentices were divided into groups and were rotated through different training areas (e.g., industrial wiring, domestic wiring, sheet-metal work,

and drawing). Installation testing formed a major part of the domestic wiring course, which ran for 1 week. The installation testing notes were distributed by the course instructor to apprentices on the second day of the domestic wiring course. The course instructor randomly allocated subjects to either a modified or a conventional instructions group with 14 subjects in each group. The experimenter and the senior instructor who were to carry out tests did not have access to information on the group to which each subject was allocated. The notes were used by the apprentices throughout the remainder of the course and formed a regular part of their training. Other aspects of the training program in installation testing were practical demonstrations of equipment and written board work, which were common to both groups. Apprentices had access to the notes at all times, including when they were engaged in practical work.

There were three test periods, including two follow-up tests. The first test was conducted at the end of the 1-week course. Apprentices were required to attempt the written test on installation testing, described in the materials section. They were tested in their respective groups and allowed a maximum of 15 min to complete the test.

The first follow-up test was practical in nature and took place 1 week after the completion of the domestic wiring course. Apprentices were required to perform both practical tests as described in the materials section. All apprentices were tested individually. Apprentices did not have access to their notes during these tests. The first practical test involved four individual tests of an electrical appliance. Apprentices were allowed a maximum of 1 min to perform each test. After each test, the experimenter inspected the work and scored it. The same procedure was used for the second practical test, which involved two tests of an intermediate light switch. After each of these light switch tests, a senior instructor inspected and scored them.

A second follow-up test was conducted approximately 12 weeks after the completion of the domestic wiring course. Apprentices were required to attempt for a second time the written test on installation testing. The same procedure used for the first written test was employed. After completing the written test, the

TABLE 1  
The Design of Experiments 1 and 2

	<i>Acquisition</i>	<i>Test</i>		
		<i>Period 1 (Immediate)</i>	<i>Test Period 2 (1-Week Follow-Up)</i>	<i>Test Period 3 (12-Week Follow-Up)</i>
Experiment 1	Conventional or modified instructions	Written	Written and practical	Written and practical
Experiment 2	Conventional or modified instructions	Written	Practical	Written

apprentices were required to reattempt the first practical test using the electrical appliance. The test procedure was the same as for the first follow-up. For practical reasons, testing of a light switch could not be carried out during the second follow-up. Table 1 provides a diagram of the experimental design.

## Results and Discussion

Table 2 indicates the mean scores for the two groups on all written and practical tests. A 2 (Groups)  $\times$  2 (Test Periods) analysis of variance (ANOVA) with repeated measures on the last factor was calculated to assess any written test differences between the two groups. (Written tests were conducted during the first and third test periods; see Table 1.) Results showed a significant main effect for groups in the predicted direction,  $F(1, 26) = 8.60$ ,  $MS_e = 553.14$ , suggesting an overall superiority of modified instructions. (The .05 level of significance is used throughout this article unless otherwise stated.) The interaction between groups and test periods was not significant,  $F(1, 26) = .63$ ,  $MS_e = 7.14$ , indicating a similar pattern of results, favoring the modified instructions group, over both test periods. Overall, there was an improvement in written test scores from the first test period to the 12-week follow-up,  $F(1, 26) = 8.68$ ,  $MS_e = 97.79$ . This result is to be expected from increased exposure to installation testing equipment over the 12-week period. Although the performance of both groups increased over the test period, the conventional group mean scores remained well below that of the modified group. In fact, the improved mean score for the conventional group was below the mean score for the modified group in the first test period. This suggests that, even after 12 weeks of access to instructional notes and equipment, the conventional group's written test performance still had not exceeded that of the modified group's initial performance.

We suggest that the written test results are in accord with the hypothesis that modified instructions (packaged in an integrated format) imposed a lower cognitive load than conventional instructions. Because modified instructions reduced the need to reformulate the material in order to be understood, cognitive resources could be devoted to learning and revising the installation testing material. To understand the conventional instructions, apprentices presumably needed to make continual mental integrations throughout the notes to assimilate the material. These mental integrations also were probably required when the material was revised. Attention and mental resources may have been continually devoted to a task unrelated to learning. Consequently, relatively fewer resources were available for acquiring the principles of installation testing.

Practical tests were conducted during the second and third test periods (see Table 1). Of the 28 apprentices originally tested, only 20 (10 from each group) were available for the second test period. Data from the first practical test (appliance testing using an electric kettle) were subjected to a 2 (Groups)  $\times$  2 (Test Periods) ANOVA with repeated measures on the last factor. As with the written

TABLE 2  
Written Test and Practical Test Scores  
for the Three Testing Periods of Experiment 1

Group	Test Period				
	1		2		3
	Written Test	Practical		Written Test	Practical Test 1
		Test 1	Test 2		
Conventional					
<i>M</i>	8.2	1.9	1.2	10.1	2.1
<i>SD</i>	7.3	1.2	0.9	5.6	1.8
Modified					
<i>M</i>	13.8	4.5	1.9	17.1	5.4
<i>SD</i>	6.2	1.8	1.5	5.3	1.2

test results, there was a significant main effect due to groups,  $F(1, 18) = 33.72$ ,  $MS_e = 87.03$ . The Class  $\times$  Test Period interaction was not significant,  $F(1, 18) = .58$ ,  $MS_e = 1.22$ , indicating a similar pattern of results over the second and third test periods. There was no overall difference in practical test performance between the second and third test periods,  $F(1, 18) = 1.42$ ,  $MS_e = 3.02$ .

The second practical test was conducted once only (in the second test period; see Table 2). There was no significant difference between the two groups on the second practical test,  $t(18) = 1.24$ , although the direction was as predicted.

In general, the practical test results, like the written test results, favored the modified instructions group. These findings indicate that the hypothesized advantages of integrated instructions transfer to related practical skills as well as performance on written tests.

The findings of this experiment have considerable significance. They suggest that integrated instructional formats are superior to conventional split-source formats. We consider them important for a number of reasons. First, they were obtained in an industrial training setting that is rarely used in experiments based on cognitive theory. Second, the results were attained using detailed and lengthy instructional notes. Last, and most important, the differences between the two groups in both written and practical skills persisted throughout the 3-month study. Cognitive load theory generated the experiment and the result. We assumed that integrated instructions would reduce cognitive load and allow attention to be directed to acquiring knowledge of installation testing principles. The results indicated that this knowledge continued to affect performance over a relatively long period and, based on the final tests, may have assisted in the acquisition of further skill. Conversely, we hypothesized that the conventional split-source format, which required numerous mental integrations, misdirected attention and imposed a relatively heavy cognitive load, leaving fewer cognitive resources available for ac-

quisition of the installation testing principles. Less learning by the conventional instruction group is in accord with this hypothesis.

It should be pointed out that, because of the realistic environment used in this study, there were no direct measures of cognitive load. Rather, the experiment was generated by and the results are in accord with cognitive load theory. Normally, differences in time required to study learning materials may be used to indicate differences in the cognitive load imposed by the materials. Such measures were not possible in this study. It might be noted that differences in study times favoring integrated materials were obtained by Sweller et al. (1990) using laboratory studies. In addition, it was possible to record study times in some of the subsequent experiments reported in the current article.

## EXPERIMENT 2

Experiment 1 focused on instructional materials that required learners to integrate multiple sources of information mentally, because the instructions were not intelligible in an unintegrated form. Units of information that are unintelligible unless they are integrated, either mentally or physically, with other units of information, are quite common in mathematics, science, engineering, and other technical areas. Nevertheless, we need to ask whether integration of disparate sources of information is always beneficial. In some areas, mental integration is not essential, because one source of information may be intelligible by itself. For example, a diagram may be fully understandable without reference to related textual information; similarly, textual information may be intelligible without reference to a related diagram. This possibility raises a number of interesting questions. The findings of Experiment 1 confirmed the superiority of integrated instructional formats in areas where mutually referring sources of information needed to be assimilated in order to be understood. It was assumed that conventional instructional formats, which require mental integrations to be intelligible, misdirect attention and impose a heavy cognitive load. However, when one source of information can be understood separately, mental integrations are not necessary and may not occur. In these situations, people may learn quickly to attend only to one source of information and avoid unnecessary mental integrations. Under these circumstances, there is no reason to assume that integrated instructional formats will be of any benefit.

Experiment 2 was designed to compare conventional instructional formats with modified instructional formats using principles of wiring electrical light circuits. The conventional split-source instructions were very similar to those regularly used by the company as part of its electrical training program. The modified instructions contained virtually the same information but in an integrated format. The experiment was conducted at the same time and used the same subjects as Experiment 1. Unlike the previous experiment, mutually referring sources of in-

formation did not necessarily need to be integrated in order to be understood. For example, diagrams could be understood without reference to their accompanying text. Understanding could occur without expending mental resources in the process of integration. As a consequence, physical integration may not reduce cognitive load.

Figure 3 provides an example of a diagram that is intelligible without reference to the accompanying text. Consider the first textual statement: "The active wire goes from the active to the common of Switch 1." This statement adds nothing to information that can be obtained by studying the diagram. In fact, all of the statements except the sixth are basically redundant. As a consequence, the integration of Figure 4 may not assist intelligibility.

The text-diagram redundancy of Figures 3 and 4 can be contrasted with the text associated with the diagram of Figure 1 used in Experiment 1. The first sentence that refers to the diagram reads: "Make sure main switch is 'on' and all fuses are 'in.'" This information is not likely to be gleaned from the diagram. Similarly, none of the remaining statements provides redundant information that

Internal wiring for intermediate switching

1. The active wire goes from the active to the common of switch 1
2. In this type of switching we use an additional switch called the intermediate switch
3. The wires connecting switch 1 to the intermediate switch and to switch 2 are called strap wires
4. The switch wire goes from the common of switch 2 to the light
5. The neutral wire goes from the light to the neutral
6. Under no circumstances is the gauge of wire used in this type of circuit to be broken.

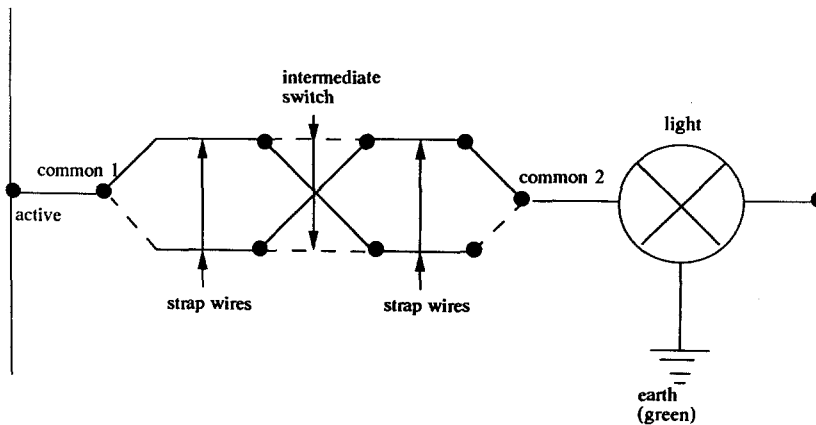

FIGURE 3 Example of the instructional format presented to the conventional group of Experiment 2.

Internal wiring for intermediate switching

FIGURE 4 Example of the instructional format presented to the modified group of Experiment 2.

could be obtained readily from the diagram. The advantages of using integrated material (Figure 2) become manifest.

The aim of Experiment 2 was to investigate possible differences between conventional and integrated instructions in an area where there was no absolute necessity for sources of information to be mentally integrated in order to be intelligible. Figures 3 and 4 exemplify some of the materials used.

### Method

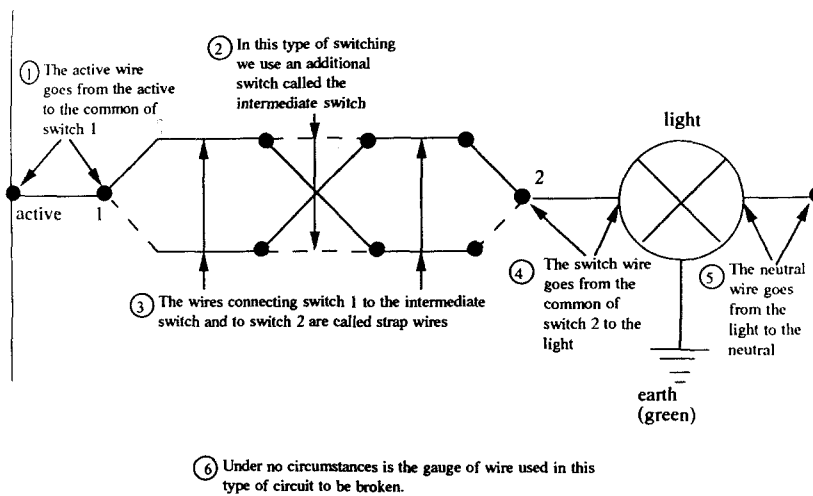
**Subjects.** The subjects were 28 first-year trade apprentices from a Sydney company. No subjects had any previous training in wiring lighting circuits.

**Materials.** There were two sets of instructional notes on lighting: conventional and modified. Both sets of notes were designed to introduce apprentices to lighting in domestic areas. The conventional instructional notes, in the form of a 10-page booklet, were virtually identical to the regular instructions used by the company as part of its electrical apprentice training program. As with Experiment 1, the very minor revisions made to the instructions were only in the interests of clarity. The main emphasis on the notes was on introducing apprentices to various electrical light circuits (e.g., single light, two-way switching, intermediate switching, and fluorescent light). The conventional notes for each

lighting circuit were in a conventional split-source format, with an internal wiring diagram and a written explanation of the circuit presented separately. An example of the conventional format for an electrical light circuit is presented in Figure 3. As indicated before, the diagrams of the electrical circuits could be understood without reference to the accompanying textual information. In addition to the notes on electrical circuits, there were notes on the operating principles of fluorescent lamps. These notes also were presented in a split-source format, with a diagram of a fluorescent lamp and related textual information presented separately. The textual information could be understood without reference to the diagram.

The modified instructional notes contained the same information but in an integrated format. Mutually referring sources of information were integrated, where possible, into unitary sources of information. An example of an electrical circuit in a modified format is displayed in Figure 4.

The test materials consisted of a test booklet, as well as the apparatus for practical tests. The test booklet was divided into five sections that covered questions on each electrical circuit and operating principles of fluorescent lamps. The questions on electrical circuits simply required subjects to identify components and wires from internal wiring diagrams. This was the method by which the company usually assessed apprentices' knowledge of electrical circuits. As one example, subjects were presented with the internal wiring of a fluorescent light and asked to label specific components of the diagram, such as the switch and neutral and active wires.

In total there were 31 questions. As with Experiment 1, questions were marked as either correct or incorrect. One mark was allocated for a correct response, whereas no mark was given for an incorrect response.

There was one practical test, which required apprentices to completely construct an intermediate light switch. The materials required for this test were an electrical training board (a board used by apprentices to construct different light switches), various wires, and electrical tools. This was the practical method by which the company usually assessed apprentices' knowledge of an electrical circuit. Assessment of this test was simple and completely objective, because the intermediate light switch could only be classified as operative or inoperative. A senior electrical instructor tested each apprentice's light switch separately and judged whether the circuit was operative.

*Procedure.* The procedure was similar to that of Experiment 1. The experiment was conducted as part of the normal training program of the company. The lighting notes were distributed by the course instructor to apprentices on the second day of the domestic wiring course. Subjects were randomly allocated to either a modified or a conventional instructions group. The notes were used by the apprentices throughout the remainder of the week-long course. They had access to the notes at all times, including when they were involved in practical work.



As with Experiment 1, the experimenter and senior instructor were unaware of the actual allocation of apprentices to groups.

There were three test periods, including two follow-up tests. The first test was conducted at the end of the course. Apprentices were required to attempt the written test on lighting. They were tested in their respective training groups and allowed a maximum of 15 min to complete the test.

The first follow-up test (the second test) was practical in nature and took place 1 week after the completion of the domestic wiring course. Apprentices were required to perform the practical test of constructing an intermediate light switch. They were tested in their respective groups. Each apprentice was given an electrical training board and had access to appropriate wires and electrical tools. The apprentices were given up to 40 min to complete the task and did not have access to their lighting notes. After an apprentice was satisfied the task was complete, a senior instructor tested the circuit and classified it as either operative or inoperative. An experimenter recorded these results.

A second follow-up test (the third test) was conducted approximately 12 weeks after the completion of the domestic wiring course. Apprentices were required to reattempt the written test on lighting. The same procedure used for the first written test was employed. For administrative reasons, it was not possible to run a follow-up practical test. The experimental design is displayed in Table 1.

## Results and Discussion

Mean scores for the two groups on all written and practical tests are displayed in Table 3. Written test data from the first and third tests were subjected to a 2 (Groups)  $\times$  2 (Test Periods) ANOVA, with repeated measures on the last factor. Inspection of means indicated that the conventional group performed marginally better than the modified group on both test occasions. Nevertheless, there was no significant difference between the groups,  $F(1, 26) = 1.76$ ,  $MS_e = 64.29$ . In addition, there was no performance difference between the test periods,  $F(1, 26) = .02$ ,  $MS_e = .29$ , and a nonsignificant Group  $\times$  Test Period interaction,  $F(1, 26) = 2.43$ ,  $MS_e = 34.57$ .

Of the original 28 apprentices, only 20 (10 from each group) were available for the practical test. Seven of the 10 apprentices from the conventional group successfully constructed an intermediate light switch. This compared with four successful constructions from the modified group. A Fisher Exact Test on these frequencies failed to find any significant difference between the two groups.

The findings of this experiment are clearly different from Experiment 1, which found strong effects favoring modified, integrated instructions. The current experiment did not provide any evidence for the superiority of modified instructions. We believe that these results are in accord with the theory used to generate the experiments. As mentioned earlier, the materials used in this experiment were very different from those of Experiment 1. The instructional materials of the

TABLE 3  
 Written Test Scores and the Number of Subjects Successfully Completing  
 the Practical Task for the Three Testing Periods of Experiment 2

Group	Test Period		
	1	2	3
	Written Test	Practical Test	Written Test
Conventional			
<i>M</i>	19.4	7	18.0
<i>SD</i>	6.9		4.2
Modified			
<i>M</i>	15.7	4	17.4
<i>SD</i>	5.2		3.1

previous study required learners in the conventional group to integrate disparate sources of information mentally, because the instructions were unintelligible in an unintegrated form. Experiment 2 used instructions that did not necessarily require sources of information to be mentally integrated in order to be intelligible. As a consequence, physical integration did not yield any benefits.

Experiments 3 and 4 were laboratory type experiments conducted to test the possibility that in some instructional areas a single, meaningful source of information is superior to multiple sources of information in either an integrated or a conventional, split-attention format. By running the experiments under laboratory conditions rather than the realistic conditions of Experiments 1 and 2, it should be possible to obtain more direct data relevant to the theoretical constructs used to generate the experiments. For example, we have hypothesized that effects that show up during test periods are due to differences in cognitive load during acquisition. Although time spent in acquisition may be used as an indicator of cognitive load, it could not be measured in the previous experiments because of the environment in which they were run. It was measured in the subsequent experiments.

### EXPERIMENT 3

In Experiment 2, it was hypothesized that apprentices given the conventional instructions would quickly realize that the lighting material contained redundancies and that they could avoid unnecessary mental integration by attending to only one meaningful source of information, usually in the form of an internal wiring diagram. As a consequence, nothing was gained by integrating text and diagrams for the modified group. Experiment 3 was designed to test this hypothesis.

Two groups were used. Both groups were given conventional instructions for a direct on-line (DOL) starter control circuit, a circuit used in industrial electrical

areas. The instructions consisted of an internal wiring diagram of the circuit, as well as related textual information describing the circuit. The internal wiring diagram could be fully understood without reference to the textual information.

The implicit instruction group was simply asked to study the instructions. The explicit instruction group was not only asked to study the instructions but was also instructed to make sure the textual information was read and related to the diagram. Because the explicit instruction group was clearly instructed to assimilate the textual information, it might be expected that this group would direct attention and cognitive resources to mentally integrating the two sources of information, rather than to understanding the circuit. If such use of cognitive resources by the explicit instruction group occurs, it can be predicted that the implicit instruction group would exhibit superior knowledge of the DOL starter control circuit because many of them might ignore the textual information and devote attention and mental resources to the diagram.

It might be noted that this experiment does not directly test the hypothesis that the implicit instruction group attends to the diagram to the exclusion of the text. Nevertheless, given that the diagram contains all necessary information and given that we know that diagrammatic information normally is massively easier to process than the equivalent textual information (see Larkin & Simon, 1987), it is reasonable to predict that the implicit group will exhibit superior performance due to these subjects attending primarily to the diagram.

## Method

*Subjects.* The subjects were 20 first-year apprentices from a Sydney company. The subjects had only limited experience in industrial electrical areas. All subjects had previous exposure to circuits with internal wiring diagrams and related textual information. Sixteen of the 20 subjects had no previous exposure to a DOL starter control circuit. The remaining 4 subjects had very briefly viewed a DOL starter control circuit within the context of a larger DOL circuit. To ensure a balanced experiment, 2 of these subjects were randomly allocated to the first group and 2 subjects were randomly allocated to the second group.

*Materials and procedure.* Subjects were allocated randomly to either a group directed explicitly to study both the text and diagram and to relate them—called the explicit instruction group—or to a group merely presented both text and diagram without explicit instructions to study both—called the implicit instruction group. All subjects were tested individually. The experiment was conducted in two phases. The first phase was the instruction phase. The experimenter began this phase by informing subjects that they would be asked to study some instruction material for a DOL starter control circuit that would be followed by a number of test problems. Subjects in the implicit group were asked simply to

study the instructional material. Subjects from the explicit group were given similar instructions but also instructed to read the textual information and relate it to the diagram. The instructional materials for both groups are given in Figure 5. The subjects were asked to read the instructional material at their own pace and to indicate when they had finished reading. Time for completion was noted.

A test phase followed. Three problems were presented, one at a time. Instructional materials were not available to apprentices during testing. Subjects were permitted unlimited time on each problem. The first test problem required them to construct and label a DOL circuit. The second problem consisted of a slightly different diagram from the DOL presented to subjects in the instructions. The diagram differed from the original in the following ways: (a) The active was located below the rest of the circuit; (b) the fuse was located directly below the thermal overload contact (TOC); and (c) the wire between the fuse and the TOC was shorter. Subjects were asked to label the components of this diagram. The third problem consisted of three questions requiring written responses. Subjects were asked to indicate where specific components of the circuit were located. The first question asked for the starting and finishing positions of the neutral wire (see Figure 5).

Wiring of a Direct On Line (D.O.L) Starter Control Circuit

- 1) The active wire goes from the active to the fuse.
- 2) From the fuse to the Thermal Overload Contact (T.O.C).
- 3) From out of the T.O.C. to the stop button.
- 4) The circuit is then wired from the stop button to the start button and from stop button to one side of holding contact (Z4).
- 5) Then from the start button to the contactor coil and from the start button to the other side of holding contact (Z4).
- 6) The neutral wire goes from the contactor coil to the neutral bar.

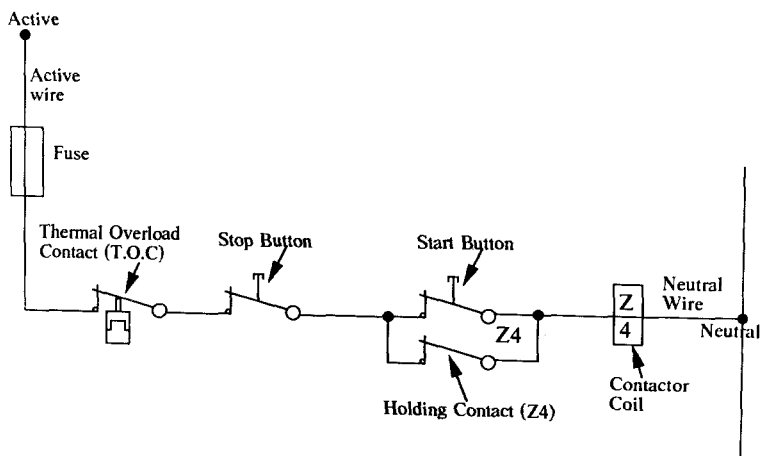

FIGURE 5 Instructional material presented to both groups of Experiment 3.

The second question asked for the starting and finishing positions of the active wire. These two questions required two written responses each. The third question asked for the component that was located between the fuse and the stop button. Only one response was required for the third question. Thus, the third problem consisted of three questions requiring five written responses.

### Results and Discussion

Table 4 indicates mean instruction times and test scores for both groups. A *t* test indicated that the implicit group, which was asked simply to study the material, spent significantly less time processing the instructions than the explicit group, which, in addition to being asked to study the material, was instructed to assimilate the text with the diagram,  $t(18) = 3.28$ . The difference between the groups was quite large, with the explicit group spending almost twice as much time processing instructions as the implicit group.

This result is consistent with the cognitive load hypothesis. Assume subjects from the implicit group quickly realized the nature of the instructions and avoided unnecessary mental integrations. Instead, they directed their attention and mental resources to the self-explanatory diagram. As a consequence, cognitive load was reduced. A reduction in cognitive load by the implicit group is consistent with the relatively rapid rate at which the material was assimilated.

Test scores for each problem were calculated as follows. The first problem required apprentices to construct and label a DOL circuit similar to the one presented during the instruction period. One mark was allocated for each component in its correct position. One mark was also allocated for each correct label. In total, 30 marks were allocated for the first problem. The second problem required apprentices to label (but not construct) a diagram that differed from the one presented during instruction. One mark was allocated for each correct label, giving a total out of 12. The third problem required five written responses. One mark

TABLE 4  
Instruction Times (in Seconds) and Test Scores  
on the Problems of Experiment 3

Group	Instruction Time	Problem		
		1	2	3
Implicit				
<i>M</i>	32.3	23.9	8.0	3.4
<i>SD</i>	15.1	1.0	0.7	1.9
Explicit				
<i>M</i>	62.6	21.6	7.5	2.7
<i>SD</i>	25.0	3.9	1.4	1.6

was allocated for each correct response, giving a total out of five. The implicit group scored significantly higher (using a one-tailed test) than the second group on the first test problem,  $t(18) = 1.81$ . Although the direction was as predicted, there was no significant difference between the groups on the second problem,  $t(18) = 1.05$ , or the third problem,  $t(18) = .90$ . The lack of significant effects on the second and third problems may be due partly to the reduced marking scale available for these problems. The first problem could be marked out of 30, but the second and third problems could only be marked out of 12 and 5 marks, respectively.

The findings from this experiment favor the implicit instruction group. Despite spending substantially less time on the instructional material, this group performed significantly better than the explicit instruction group on the first test problem. The direction of results for the other two problems also favored the first group. The findings of the study are consistent with the view that apprentices from the implicit instruction group, who were simply asked to study the instructions, rapidly identified the nature of the instructional material, abandoned attempts at unnecessary mental integrations, and instead directed attention and mental resources solely to the diagram. On the other hand, it is possible that the explicit instruction group, which was clearly instructed to assimilate the textual material and the diagram, unnecessarily directed attention and cognitive resources to this task. If the explicit instruction group behaved in this manner, fewer resources would have been available for acquiring knowledge of the circuit.

#### EXPERIMENT 4

In Experiment 3, we showed that instructing apprentices to mentally integrate redundant textual information with a self-explanatory diagram impeded knowledge of an electrical circuit relative to neutral instructions to learn the materials. If redundant textual information is a handicap to learning, its removal may be an important step in improving instructional formats. Experiment 4 was designed to test this hypothesis using a mixed electrical circuit. These circuits are used extensively in domestic electrical areas.

There were three groups in the experiment. The first group received a diagram of the internal wiring of a mixed circuit only. A second group received the instructions in a conventional format, with textual information presented separately to the internal wiring diagram. This group was specifically instructed to assimilate the textual material with the diagram. A third group was given the instructions in a modified, integrated format. We predicted that the diagram-only group would exhibit superior performance to the conventional and modified groups, because attention and mental resources could be devoted entirely to studying the one essential source of information—the diagram.

## Method

**Subjects.** The subjects were 20 first-year apprentices from a major Sydney company. The subjects had some experience in domestic electrical areas. All subjects had previous exposure to internal wiring diagrams and related textual information. No subjects had seen instructions for a mixed circuit.

**Materials and procedure.** Subjects were randomly allocated to a diagram-only, conventional, or modified group. The experiment was conducted in two phases, and all subjects were tested individually. During the instruction phase, subjects were informed that they would be asked to study some instructional material for a mixed circuit that would be followed by a number of test problems. Subjects from the conventional group were also instructed to read the textual information and relate it to the diagram. The different versions of the materials are given in Figures 6 and 7. The subjects were asked to study the materials at their own pace and to indicate when they had finished. An experimenter noted the time for completion of instructions.

During the test phase, three problems were presented individually, and no time limit was imposed. The first test problem required subjects to construct and label a mixed circuit. The second problem consisted of a slightly different diagram from the mixed circuit presented to subjects in the instructions. This diagram differed from the original in that the general purpose outlet and associated earth wire were located above the rest of the circuit. Subjects were asked to label the components of the diagram. The third problem consisted of three questions requiring eight written responses. As with Experiment 3, subjects were asked to indicate where specific components of the circuit were located. The first question of the third problem asked for the starting and finishing position of the switch wire (see Figure 6 or Figure 7). The second question asked for the starting and finishing positions of the active wire. These two questions required two written responses each. The third question asked for the starting positions and finishing positions of the primary switch wires. Four responses were required for this question, because there were two primary switch wires.

## Results and Discussion

Mean instruction times and problem test scores for all groups are presented in Table 5. Planned contrasts using an ANOVA were run. The diagram-only group required significantly less time to process the instructions than did the other two groups,  $t(27) = 3.08$ ,  $SE_{diff} = 14.43$ . The modified instructions group spent significantly less time processing instructions than the conventional instructions group,  $t(27) = 4.34$ ,  $SE_{diff} = 24.99$ .

These results are as expected. The diagram-only group, with only one source of information to attend to, quickly processed the instructional material. The

Wiring of a mixed circuit.

- 1) The active wire goes from the active to the common of SW 1.
- 2) The primary switch wire actually consists of two wires. The first goes from terminal 1 of SW 1 to the common of SW 2. The second goes from terminal 1 of SW 1 to the active at the general purpose outlet (GPO).
- 3) Strap wires are connected between terminals 1 to 1 and 2 to 2 of SW 2 and SW 3.
- 4) The switch wire goes from the common of SW 3 to the active at the light.
- 5) The neutral wire has two parts. The first goes from the neutral at the light to the neutral bar. The second goes from the neutral at the GPO to the neutral bar.
- 6) The earth wire has two parts. The first goes from the light to earth. The second goes from the earth at the GPO to earth.

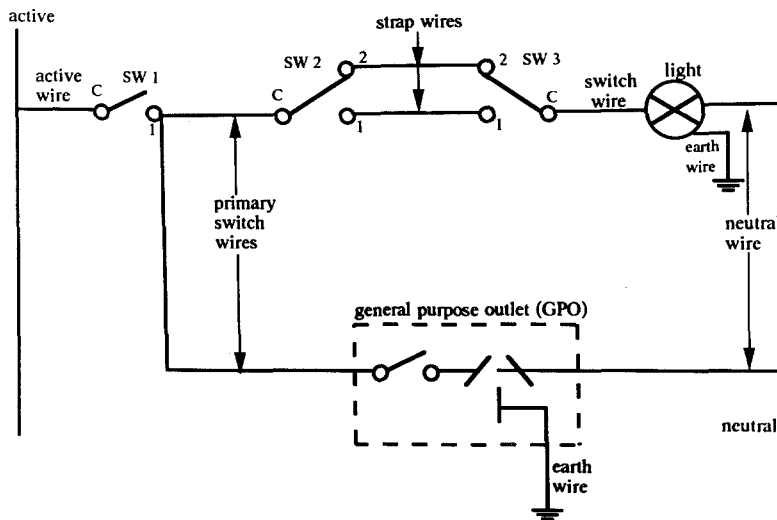

FIGURE 6 Instructional material presented to the diagram-only and the conventional groups of Experiment 4. The diagram-only group was not presented with the explanatory text.

relatively short instruction time for this group is consistent with the suggestion that cognitive load had been reduced because the group had to attend to a diagram only and not written instructions. Although subjects in the modified group had an integrated instructional format and, therefore, did not have to perform any mental integrations, they still had to process redundant written material. Thus, their instruction time was longer than that of the diagram-only group. The conventional group, which spent notably more time on the instructions than the other groups, was not only required to process redundant written information but in addition had to perform a series of mental integrations. We expected this process of mental integration to increase cognitive load and, therefore, to lengthen in-



Wiring of a mixed circuit.

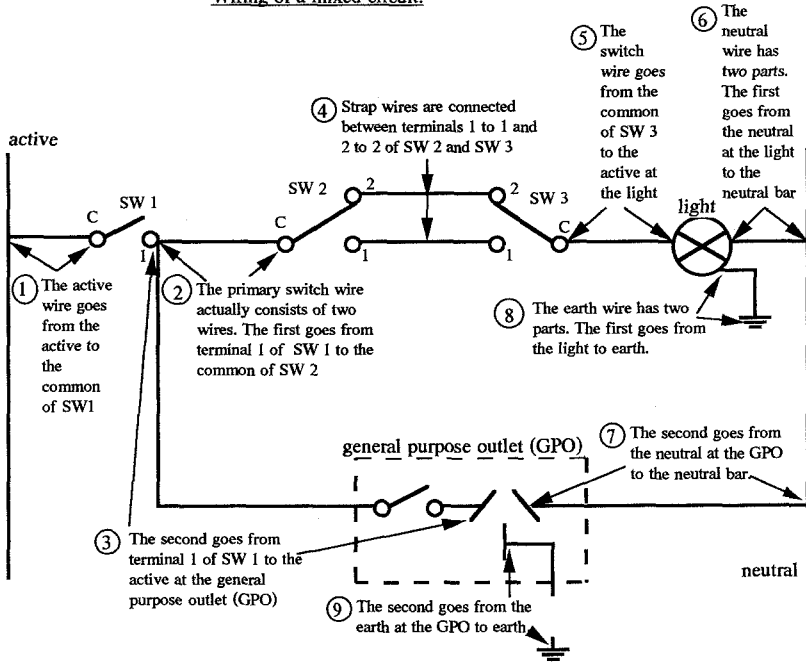

FIGURE 7 Instructional material presented to the modified group of Experiment 4.

TABLE 5  
Instruction Times (in Seconds) and Test Scores  
on the Problems of Experiment 4

Group	Instruction Time	Problem		
		1	2	3
Diagram only				
<i>M</i>	60.4	34.8	13.8	2.7
<i>SD</i>	27.9	3.5	4.2	2.4
Modified				
<i>M</i>	92.4	26.6	7.6	1.3
<i>SD</i>	18.1	8.4	3.6	1.5
Conventional				
<i>M</i>	136.9	23.2	8.8	1.9
<i>SD</i>	44.9	8.1	3.4	2.3

structional time considerably over a group that had the material physically integrated (the modified group) and even more so over a group that had the redundant textual information totally eliminated (the diagram-only group). This result was obtained.

Test scores for each problem were allocated using the same method as Experiment 3. Forty-six marks were allocated for the first problem, 22 for the second problem, and 8 for the third problem. The diagram-only group scored significantly higher than the other two groups on the first test problem,  $t(27) = 3.65$ ,  $SE_{diff} = 5.42$ , and on the second test problem,  $t(27) = 3.86$ ,  $SE_{diff} = 2.90$ . There was no significant difference between the conventional and modified groups on either the first test problem,  $t(27) = 1.09$ ,  $SE_{diff} = 3.13$ , or on the second test problem,  $t(27) = 0.72$ ,  $SE_{diff} = 1.68$ . On the third test problem, although the direction of results favored the diagram-only group, there was no significant difference between the diagram-only group and the other two groups,  $t(27) = 1.35$ ,  $SE_{diff} = 1.63$ . There was also no significant difference between the conventional and modified groups on the third problem,  $t(27) = 0.64$ ,  $SE_{diff} = 0.94$ . The lack of significant differences on the third problem may have been due to asymptotic effects. As can be seen from the means, most subjects obtained very low scores on this problem.

The results of this experiment favor the diagram-only group. Although this group spent significantly less time processing the instructions, consistent with a reduced cognitive load, it performed far better than both the conventional and modified groups on two of the test problems. The findings have direct implications for instructional formats. In areas where sources of information need not be integrated to be understood, a redundant source of information may need to be removed. The experiment showed that, by simply deleting an unnecessary source of information, instruction time was reduced, and learning was enhanced.

## EXPERIMENT 5

Experiment 4 showed that redundant textual information in either a conventional or an integrated format impeded learning. This result was obtained using electrical wiring materials. Experiment 5 was designed to test the generality of this finding by using a very different learning area. Biology materials in the form of instructions explaining the flow of blood around the heart, lungs, and body were used.

As with Experiment 4, there were three groups in this experiment. The first group simply received a single self-explanatory diagram of the heart, lungs, and body. The second group was given instructions in a conventional format, with textual information presented separately for a diagram of the heart, lungs, and body. This group was directly instructed to assimilate the textual information with the related diagram. The third group received the instructions in a modified,

integrated format. Based on the findings of Experiment 4, we predicted that the diagram-only instructions would be superior to both the conventional and the integrated instructional formats.

## Method

**Subjects.** The subjects were 30 Year 9 students from the top two of three science classes of a Sydney high school. These students had no previous exposure to instructions dealing with general circulation of blood around the heart, lungs, and body.

**Materials and procedure.** The procedure was similar to Experiment 4. Subjects were allocated to a diagram-only, conventional, or modified group. The experiment was conducted in two phases. During the instruction phase, the subjects received the instructions and were given unlimited time to process the information. Subjects in the conventional group were also instructed to read the written information and to relate it directly to the diagram.

Figures 8 and 9 display the different versions of the instructional material. The diagram-only group received a diagrammatic representation of the heart, lungs, and body. Various bodily components were labeled with arrows indicating the flow of blood. The diagram was a self-explanatory source of information. The conventional group received textual information, given below the diagram, explaining the flow of blood around the heart, lungs, and body. The modified instructions contained textual information identical to the conventional instructions but in an integrated format. Textual information explaining the flow of blood was placed at appropriate parts of the diagram.

A test phase followed. Subjects were presented with six test problems, consisting of both diagrammatic and textually orientated questions. All problems were presented individually, and once a problem was completed, it was covered from view. No time limit was placed on any of the test problems. The first problem required subjects to recall six parts of the heart. For the second problem, subjects were given an unlabeled diagram of the heart, lungs, and body and asked to label it with six parts of the heart. The third problem contained six parts. Subjects were again given an unlabeled diagram. They were asked to place six numbers on the diagram to indicate the flow of blood. For example, the first part of the third problem asks subjects to "put a 1 at the place where blood in the right atrium flows to." To complete this question, a subject simply had to write the number 1 on the unlabeled diagram at the place to which they believed blood in the right atrium flows. The remaining five parts of the question were as follows:

Put a 2 at the place where the aorta receives its blood.

Put a 3 at the place where the blood in the lungs flows to.

Diagram indicating flow of blood through the heart, lungs and body

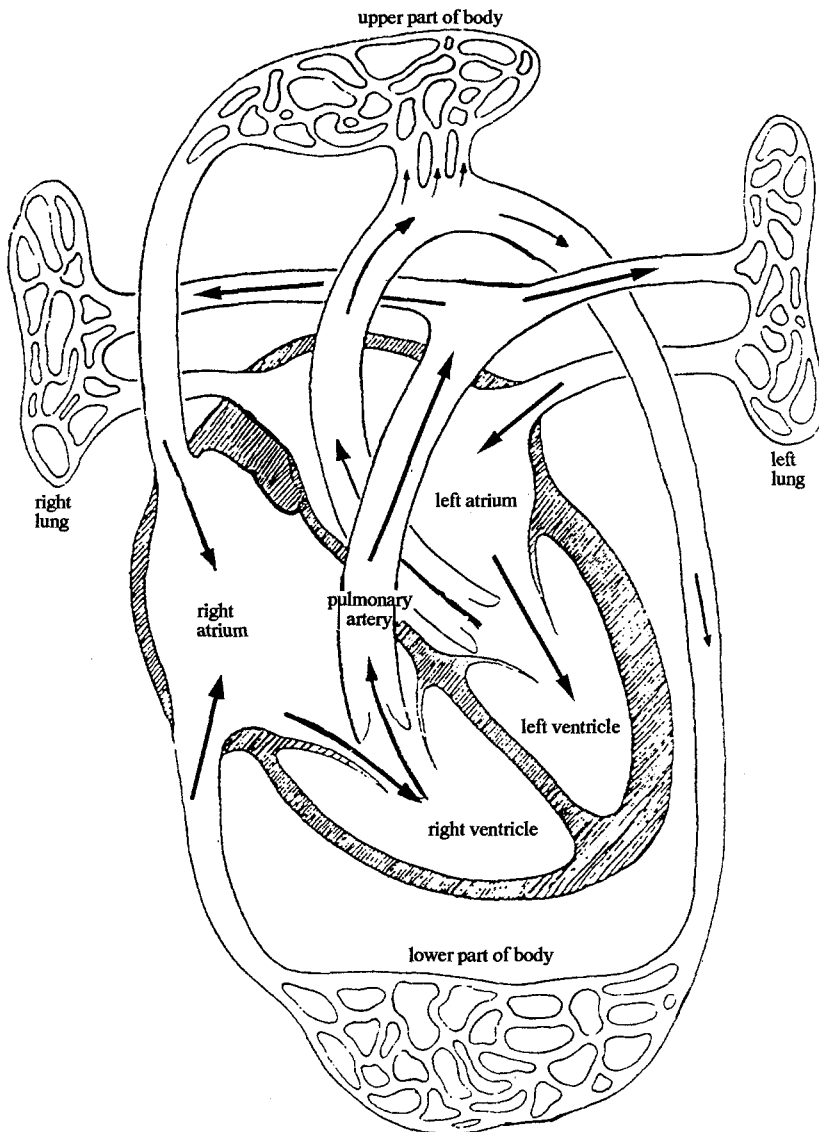

1. Blood from the upper and lower parts of the body flows into the right atrium.
2. Blood from the lungs flows into the left atrium.
3. When the ventricles relax, blood from the right atrium flows into the right ventricle.
4. At the same time blood from the left atrium flows into the left ventricle.
5. When the ventricles contract blood is forced from the right ventricle into the pulmonary artery.
6. Blood is also forced from the left ventricle into the aorta.
7. The blood entering the pulmonary artery supplies the lungs.
8. The blood entering the aorta is pumped back to the body.

FIGURE 8 Instructional material presented to the diagram-only and the conventional groups of Experiment 5. The diagram-only group was not presented with the explanatory text.

Diagram indicating flow of blood through the heart, lungs and body

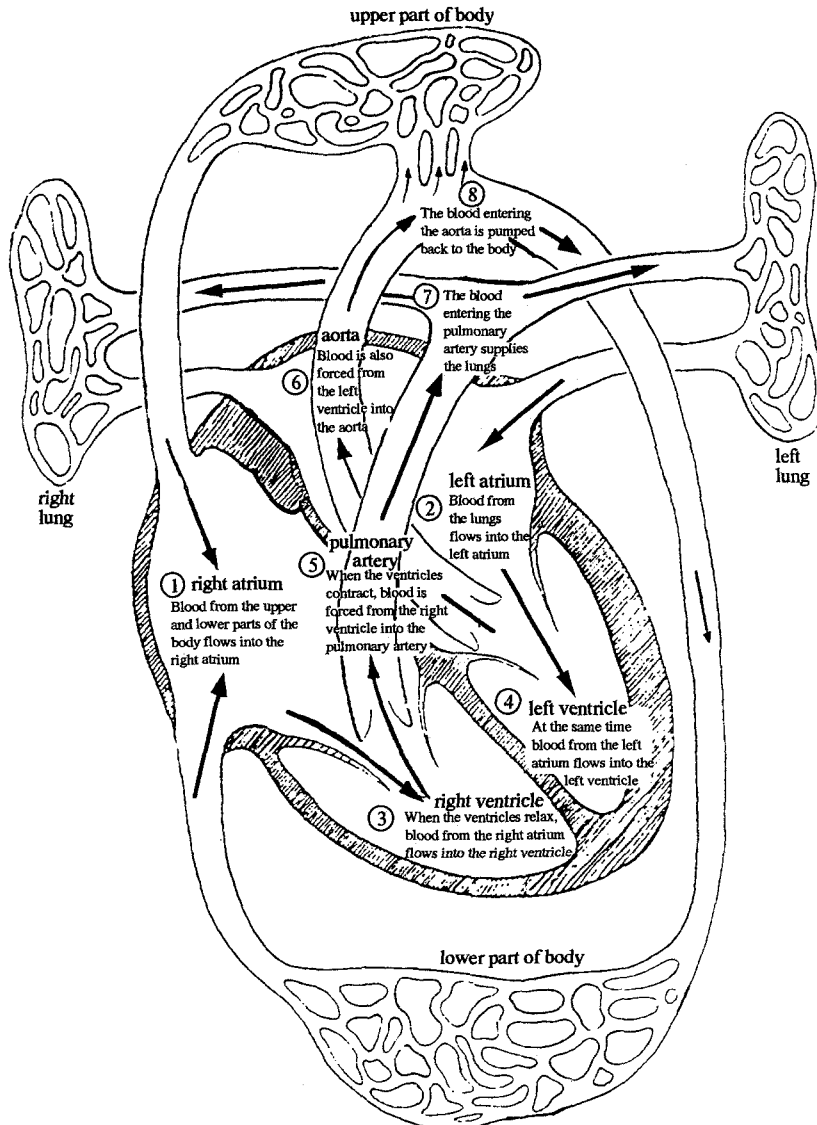

FIGURE 9 Instructional material presented to the modified group of Experiment 5.

- Put a 4 at the place where blood in the right ventricle flows to.  
 Put a 5 at the place where blood in the body flows to.  
 Put a 6 at the place where blood in the left ventricle flows to.

The fourth problem required subjects to complete two blood flow chains. A chain simply places the components in order of blood flow (e.g., left atrium → left ventricle → aorta → body). For the first chain, subjects were told that the second component of the chain was the left atrium. The subjects then were asked to complete the chain by listing the components for the first, third, fourth, and fifth positions of the chain. For the second chain, subjects were informed that the second component of the chain was the right atrium. As with the first chain, the subjects were asked to complete the chain by listing the components for the first, third, fourth, and fifth positions.

For the fifth problem, subjects were given an unlabeled diagram of the heart, lungs, and body. Unlike the diagrams for Problems 2 and 3, this diagram had lines located on it. These lines were located at the same positions as the arrows in the initial instructions diagram. To complete this test problem, subjects simply had to place an arrowhead on each line to indicate the appropriate flow of blood. The sixth problem required five written responses to questions relating to the flow of blood. They were as follows:

- Blood in the left atrium flows where?
- Blood in the right ventricle flows where?
- Blood in the left ventricle flows where?
- Blood in the pulmonary artery flows where?
- Blood in the aorta flows where?

## Results and Discussion

Table 6 displays means and standard deviations for instruction times and problem test scores for all groups. Planned contrasts using an ANOVA were run. Results indicate that the diagram-only group required significantly less time processing instructional material than the other two groups,  $t(27) = 6.81$ ,  $SE_{diff} = 18.54$ . The modified instructions groups spent significantly less time processing their material than the conventional instructions group,  $t(27) = 4.96$ ,  $SE_{diff} = 10.70$ . These results replicate those of Experiment 4.

Test problem scores were calculated as follows. The first problem simply asked subjects to name six parts of the heart. One mark was given for each correct response, giving a total out of six. The second problem required subjects to label a diagram with six parts of the heart. One mark was allocated for each heart component in its correct position, giving a mark out of six. Problem 3 required

TABLE 6  
Instruction Times (in Seconds) and Test Scores  
on the Problems of Experiment 5

Group	Instruction Time	Problem					
		1	2	3	4	5	6
Diagram only							
<i>M</i>	69.1	5.3	4.9	3.7	3.5	14.9	1.8
<i>SD</i>	12.0	1.2	1.5	2.1	2.8	1.4	1.5
Modified							
<i>M</i>	105.7	4.5	2.8	1.7	1.4	7.8	0.9
<i>SD</i>	9.6	1.2	2.4	1.6	2.1	4.5	1.1
Conventional							
<i>M</i>	158.8	3.5	1.7	0.8	1.1	7.6	0.9
<i>SD</i>	38.5	1.2	1.3	0.8	1.5	4.1	0.9

subjects to place six numbers at various parts of an unlabeled diagram. One mark was allocated for each number in its correct position, again giving a score out of six. Problem 4 asked subjects to complete two blood flow chains. Each chain required four responses. For both chains, one mark was allocated for each component in its correct position on a chain, giving a total out of eight. The fifth problem asked subjects to place arrowheads on 16 lines to indicate the appropriate flow of blood. One mark was given for each arrowhead in its correct position, giving a score out of 16. Problem 6 required five written responses. One mark was allocated for each correct response, giving a mark out of five.

Results indicate that the diagram-only group scored significantly higher than the other two groups on the first five test problems. The critical  $t$  values were:  $t(27) = 2.86$ ,  $SE_{diff} = 0.91$  for Problem 1;  $t(27) = 3.78$ ,  $SE_{diff} = 1.40$  for Problem 2;  $t(27) = 3.99$ ,  $SE_{diff} = 1.23$  for Problem 3;  $t(27) = 2.63$ ,  $SE_{diff} = 1.71$  for Problem 4; and  $t(27) = 5.16$ ,  $SE_{diff} = 2.79$  for Problem 5. Although the direction was as predicted for Problem 6, the difference was not significant,  $t(27) = 1.92$ ,  $SE_{diff} = 0.94$ . This result may still have represented a real effect,  $.05 < p < .1$ . All three groups recorded low marks on Problem 6. Despite this, the mean test score for the diagram-only group was still double that of both the modified and the conventional groups.

Although the direction of results favored the modified group over the conventional group for the first five test problems, none of the differences was significant. Both groups recorded equal means for the sixth test problem. The critical  $t$  values were:  $t(27) = 1.91$ ,  $SE_{diff} = 0.52$  for Problem 1;  $t(27) = 1.36$ ,  $SE_{diff} = 0.81$  for Problem 2;  $t(27) = 1.27$ ,  $SE_{diff} = 0.71$  for Problem 3;  $t(27) = 0.30$ ,  $SE_{diff} = 0.99$  for Problem 4;  $t(27) = 0.12$ ,  $SE_{diff} = 1.61$  for Problem 5; and  $t(27) = 0.00$ ,  $SE_{diff} = 0.54$  for Problem 6. Although there was no significant difference between the modified and the conventional groups on the first

test problem, the difference favoring the modified group may still have represented a real effect,  $.05 < p < .1$ .

As with Experiment 4, the results of this study clearly favored the diagram-only group. Despite spending far less time processing instructional materials, this group exhibited superior performance over both the modified and the conventional instruction groups. The experiment extended the findings of Experiment 4 in two ways. First, unlike Experiment 4, the diagram-only group was superior to the other two groups on both diagrammatic and textually based questions. Second, the benefits of eliminating unnecessary textual information have been shown to be effective in a very different learning area, suggesting that this finding may have considerable generality.

These results are in accordance with the suggestion that subjects in the conventional group were required to direct attention and mental resources to assimilating redundant text with the diagram. As a result, attention may have been unnecessarily misdirected away from the self-explanatory diagram, and mental resources used in integrating the text and diagram may have been unavailable for learning. These constructs were used to hypothesize poor test performance. In fact, the conventional group means in Experiment 5 fell to below a quarter of the diagram-only group.

We can hypothesize that, although subjects in the modified group were not required to split attention between text and diagram, they still had to devote mental resources to processing unnecessary textual information. There are some indications that subjects in the modified group may have performed slightly better than those in the conventional group, but the performance of the modified group was still substantially below that of the subjects in the diagram-only group, who did not have to process any redundant textual information. Consequently, these differences in speed of learning are in accordance with the suggestion that subjects in the diagram-only group could solely devote attention and mental resources to processing the self-explanatory diagram.

Using very different instruction areas, data from Experiments 4 and 5 indicate that redundant information can impede learning. The finding that the simple removal of a redundant source of information can reduce instruction time and enhance learning has direct implications for instructional formats. In instructional areas where a self-explanatory source of information exists, disparate sources of information need not be integrated in order to be understood. The single, self-contained source of information should be identified, and other sources of redundant information should be removed.

## EXPERIMENT 6

Experiment 5 showed that subjects who studied a self-explanatory diagram of the heart, lungs, and body demonstrated superior test performance to subjects who received redundant textual information in addition to the diagram in either



a conventional or an integrated format. From the point of view of cognitive load theory, this result is consistent with the preceding experiments. Nevertheless, ignoring our theoretical perspective, Experiment 1 demonstrated a very large advantage to a group that was presented integrated instructions, whereas the subsequent experiments, using different materials, failed to obtain such an effect. Although the results are in accordance with cognitive load effects, they could be due to a different, unknown variable associated with the various materials used. We can reduce the likelihood of such unknown variables contaminating our results by using materials similar to those of Experiment 5 but modified in such a way that the diagram and text do not consist of self-contained, redundant materials. If the diagram cannot be understood, except by reference to the text, results similar to those of Experiment 1 should be obtained; integrated materials should be superior to disparate sources of information. Using such materials, we should find that integrated information requires substantially less study time than conventionally presented information. A reduction of study time is consistent with reduced cognitive load. A sufficiently large reduction of extraneous cognitive load should result in superior performance on subsequent test problems.

Experiment 6 used instructional materials similar to those of Experiment 5. There were two groups in the experiment. One group received its instructions on the blood flow through the heart, lungs, and body in a conventional split-source format. Unlike Experiment 5, however, the diagram was not self-explanatory. The labels for the components of the diagram were replaced with numbers. The accompanying textual information included each number with its corresponding component and an explanation of the component's role in the circulation of blood. Thus, the two sources of information needed to be mentally integrated in order to be understood. The modified instructions contained the same information in an integrated format. We predicted, for the reasons detailed before, that the modified instructions with a unitary source of information would be superior to the conventional instructions.

## Method

*Subjects.* In this experiment, the school used ungraded Year 9 science classes. The subjects used in the experiment were the top 20 students, as judged by a common science test given by the school. No subjects had previous exposure to instructions dealing with general circulation of blood around the heart, lungs, and body.

*Materials and procedure.* The procedure was the same as in Experiment 5, except that subjects were allocated to either a conventional or a modified group. In other respects, the instruction phase was conducted identically to that of Experiment 5. The conventional and modified instructions are shown in Figures 10

Diagram indicating flow of blood through the heart, lungs and body

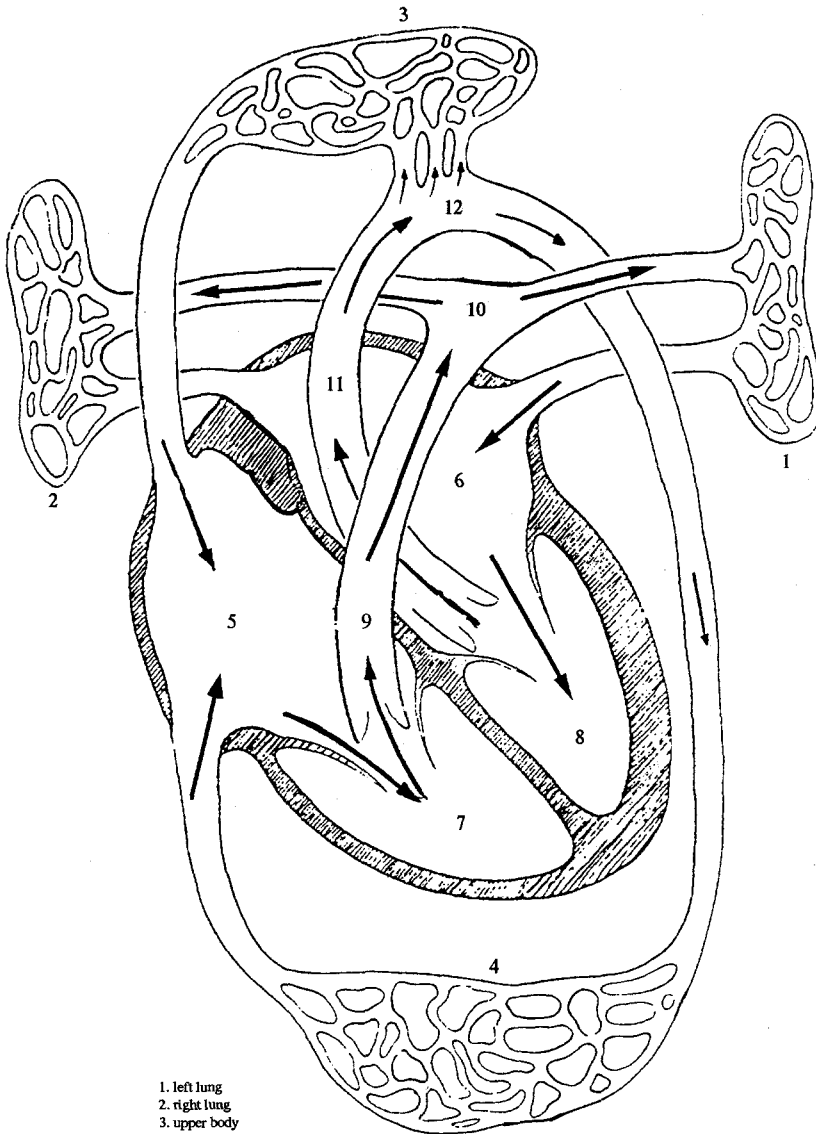

1. left lung
2. right lung
3. upper body
4. lower body
5. right atrium - Blood from the body flows into this structure.
6. left atrium - Blood from the lungs flows into this structure.
7. right ventricle - When this structure relaxes blood from the right atrium flows in.
8. left ventricle - When this structure relaxes blood from the left atrium flows in.
9. pulmonary artery - When the right ventricle contracts blood is forced into this structure.
10. Blood entering the pulmonary artery supplies the lungs.
11. aorta - When the left ventricle contracts blood is forced into this structure.
12. Blood entering the aorta is pumped back to the body.

FIGURE 10 Instructional material presented to the conventional group of Experiment 6.

Diagram indicating flow of blood through the heart, lungs and body

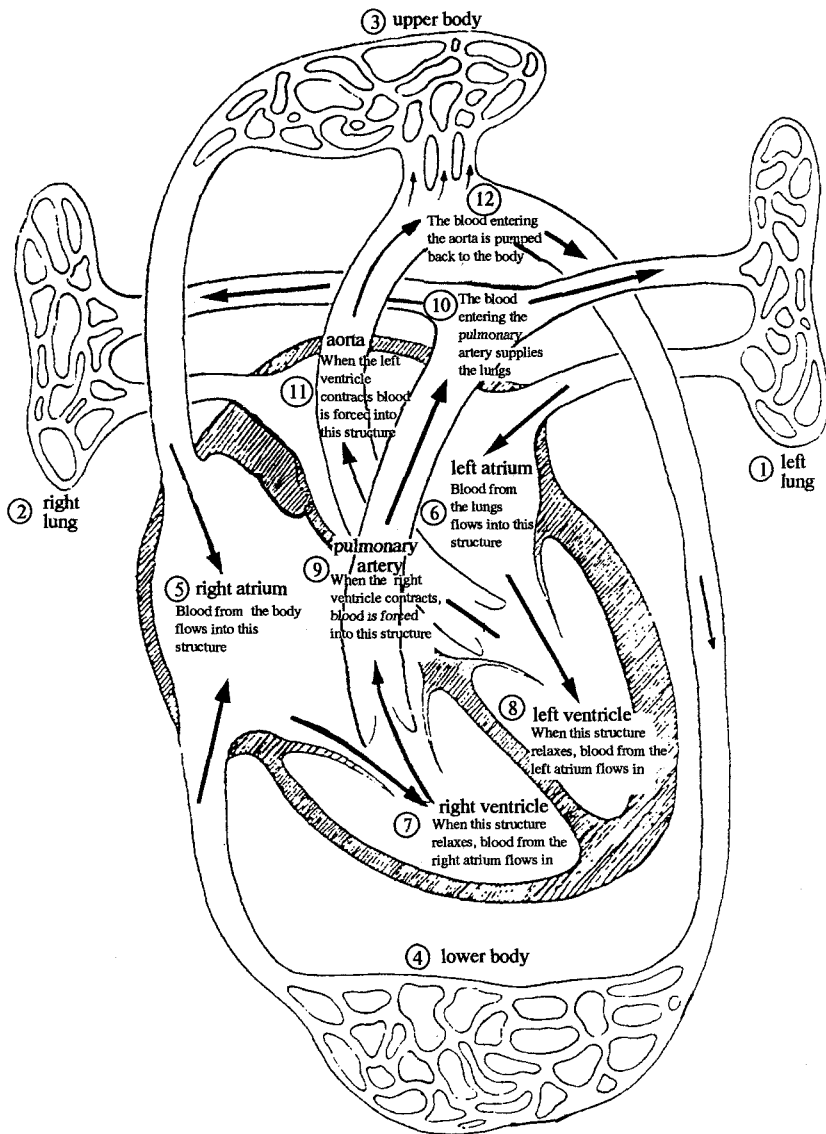

FIGURE 11 Instructional material presented to the modified group of Experiment 6.

and 11, respectively. The conventional group received textual information listed below the diagram, which contained numbers representing various bodily components. The text consisted of each number and its corresponding bodily component, along with a commentary of the role of the bodily component in the flow of blood around the heart, lungs, and body. The modified instructions contained virtually identical textual information to the conventional instructions but in an integrated format. The only difference was that the numbers were not present on the modified instructions. The test phase was conducted using the same procedure and testing materials as in Experiment 5.

## Results and Discussion

The variables under analysis were instruction time and test problem performance on each of the six test items. Means and standard deviations for instruction time and test scores are displayed in Table 7.

A *t* test indicated that the modified group spent significantly less time processing instructions than the conventional group,  $t(18) = 5.30$ . This result is consistent with a reduction in cognitive load for the modified group. We can hypothesize that subjects in the modified group simply processed their instructions by attending to the single integrated source of information. Conversely, the conventional group would have had to direct attention and mental resources to assimilating the textual information with the diagram, because each source of information was unintelligible by itself. Consequently, one would expect instruction-processing time to be considerably longer for this group. This result was achieved.

Test problem scores were calculated using the methods of Experiment 5. Six marks each were allocated to Problems 1, 2, and 3. Eight marks were allocated to Problem 4, 16 marks to Problem 5, and 5 marks to Problem 6.

Analyses using *t* tests indicated that the modified group performed significantly better than the conventional group on the first three test problems. The critical *t* values were:  $t(18) = 3.10$ , for Problem 1;  $t(18) = 2.30$ , for Problem 2; and  $t(18) = 2.40$ , for Problem 3. Although the direction was as predicted for Problem

TABLE 7  
Instruction Times (in Seconds) and Test Scores  
on the Problems of Experiment 6

Group	Instruction Time	Problem					
		1	2	3	4	5	6
Conventional							
<i>M</i>	150.8	4.0	2.7	1.7	3.3	12.8	1.7
<i>SD</i>	22.1	1.2	2.0	1.3	2.4	4.2	1.6
Modified							
<i>M</i>	105.1	5.4	4.7	3.6	4.8	13.6	2.2
<i>SD</i>	16.0	0.7	1.9	2.1	2.5	2.6	1.8

4, the difference was not significant,  $t(18) = 1.38$ . This difference may, nevertheless, represent a real effect on a one-tailed test,  $.05 < p < .1$ . The directions were also as predicted for Problems 5 and 6, although the differences between the means were quite small. Both of these findings may be due to asymptotic effects. Subjects had little difficulty with Problem 5, with both groups obtaining high scores. On the other hand, both groups obtained low scores on Problem 6.

The results of this experiment favored the modified instructions group. Despite spending less time studying the instructions, this group performed better than the conventional group on most of the test problems. These results contrast with those of Experiments 2, 3, 4, and 5, where integrated instructions did not facilitate performance on subsequent test problems. They are in accordance with the results of Experiment 1, despite vast differences in materials between Experiments 1 and 6. Thus, whereas Experiments 5 and 6 used very similar materials but obtained contrasting results, Experiments 1 and 6 used quite different materials but obtained similar results. The paradox may be resolved by an analysis of the materials in terms of the cognitive processes required to assimilate the information presented in each experiment. We can hypothesize that, in Experiments 1 and 6, students had to mentally integrate disparate sources of information when presented with conventional materials, resulting in a heavy extraneous cognitive load. In Experiments 2, 3, 4, and 5, mental integration may not have been necessary because of redundant information, and so physical integration had minimal consequences. The elimination of redundancy proved more effective. The surface structure of the materials (e.g., electrical wiring, human anatomy) proved irrelevant to these processes.

## GENERAL DISCUSSION

The experiments reported in this article have highlighted the inadequacy of some conventional methods of presenting instructional materials. We believe that these findings have some important implications. Before discussing these, however, we summarize the results.

Experiment 1 used detailed electrical notes in an industrial training setting and found that integrated instructions were superior to the conventional instructions previously used by the company. Results favoring integrated instructions in written test performance and practical skills persisted throughout the 3-month study, clearly demonstrating the long-term advantages of eliminating the need for students to split their attention between multiple sources of mutually referring information.

The advantages of the integrated instructional package used in Experiment 1 were found in an area where it was essential for two or more sources of information to be mentally integrated in order to be intelligible. In contrast, we had no theoretical reason for supposing that integrated instructions would be effective in areas where sources of information did not have to be integrated in order to

be understood. In another long-term study, Experiment 2 showed that integrated instructions were no more effective than conventional instructions in areas where it was not necessary to mentally integrate text and diagrams. It was hypothesized that subjects identified the nature of the instructional material and only devoted attention and mental resources to the one meaningful source of information.

Unlike Experiments 1 and 2, Experiments 3 and 4 were laboratory experiments designed to throw further light on the elimination of an effect favoring integrated instructions in Experiment 2. Experiment 3, using industrial electrical circuit instructions, found that subjects who were not specifically asked to integrate disparate sources of information required less instruction time and performed better than subjects who were specifically instructed to mentally integrate related text and diagrams. We suggested that redundant information could impede learning and that its removal was another necessary step in improving instructional materials. Experiment 4 provided strong evidence for this hypothesis. Using domestic electrical circuit instructions, it was found that one self-explanatory source of information was superior to two redundant sources of information in either a conventional or an integrated format.

Experiments 5 and 6 duplicated the results of the preceding experiments in a vastly different area: blood flow in the human body. Experiment 5 obtained similar results to Experiments 2, 3, and 4, with physically integrated materials having minimal effects. The elimination of redundant material proved superior. Seemingly minor alterations to the Experiment 5 materials in Experiment 6 resulted in a similar pattern of results to that obtained in Experiment 1. Integration proved superior to disparate sources of information.

## THEORETICAL CONSIDERATIONS

The experiments and predictions of this article were generated by cognitive load theory. The theory was used to hypothesize that some conventionally used instructional designs are inadequate. It also was used to design alternative modes of instruction predicted to be more effective. In general, the data supported our hypotheses.

It must be emphasized strongly that we were not engaged in a theory validation exercise. The theory was used solely to attempt to provide results with direct instructional implications. Our procedure was to use the theory to consider the cognitive consequences of some instructional designs and to predict, on the basis of those cognitive consequences, the adequacy of the formats used. We then tested the predictions by comparing learning and problem solving after the use of differing instructional designs. Direct tests of, for example, attentional or cognitive load factors were not carried out. By emphasizing instructional effectiveness, we have obtained immediate rather than merely potential applications. We believe direct applications are essential for the health of the cognitive science enterprise at this time.

Inevitably, there are both negative and positive consequences to our approach in this article. Because we have not tested cognitive processes directly in this set of experiments, there is a possibility that our findings are due to variables other than those we have postulated. Testing for cognitive processes decreases the likelihood of alternative, post hoc explanations being available for a set of results. Although we concede these points, it should be noted that many previous reports have provided evidence for cognitive load theory using verbal protocols, differential error scores and error locations, task difficulty as measured by time to completion, and dual task paradigms (e.g., see Ayres & Sweller, 1990; Owen & Sweller, 1985; Sweller, 1988; Tarmizi & Sweller, 1988). Notwithstanding this work, additional detailed tests of cognitive processes need to be carried out. Nevertheless, given that the theory was constructed solely to generate instructional applications, we feel it is essential that at some point it does just that. Furthermore, although alternative conceptualizations may be found to explain our results, currently they seem incapable of generating experiments leading directly to applications. The fact that cognitive load theory is able to do so is itself a form of incidental validation.

The major positive consequence of our approach is that, if hypotheses are supported, applications are available immediately. The ultimate aim of any theory dealing with cognition and instruction must be that it generates new and useful instructional techniques. Any other aims are merely means toward this end. Specifically, we do not feel that being able to explain results in a post hoc fashion is a substitute for generating applications. Cognitive load theory can generate instructional applications.

### INSTRUCTIONAL APPLICATIONS

The findings of the group of experiments reported in this article indicate that, in areas where mental integrations are essential in order to make sense of two or more sources of information, conventional instruction should be replaced by integrated instructional formats. In areas where mental integrations are not necessary because of redundant information, neither physical nor mental integration is beneficial. Isolation and elimination of redundant sources of information are preferable. As shown in Experiments 2, 3, 4, and 5, this is a simple process that requires little more than a quick inspection of instructions. Once the self-explanatory source of information is located, other unnecessary sources of information should be deleted.

The frequently made assumption, sometimes explicit but more frequently implicit, that redundant technical information is at least neutral and perhaps beneficial in its effects on learning needs to be called into question. Redundancy that can lead to mental integration seems to be neutral at best and then only when learners are aware that it is redundant and, therefore, ignore it. Paradoxical-

---

cally, by eliminating redundancy, intelligibility may be increased rather than decreased.

Although most of us have a pervasive intuition that redundancy can be beneficial, currently there is no information on the relevant conditions. It appears reasonable to assume that redundant information that does not or cannot lead to attempts at mental integration can be beneficial. Summaries, for example, are redundant but are not integrated normally with the original material. They are probably useful as a reminder of the preceding information. Widely separated (physically or temporally) redundancy might be beneficial as a mnemonic device. In addition, we must consider the possibility that redundant technical information can be beneficial where information is so poorly structured that almost any alternative presentation of the same material is useful, even if it does lead to attempts at mental integration.

The results of the current series of experiments using introductory instructional materials can be combined with studies using worked examples (e.g., Cooper & Sweller, 1987; Sweller & Cooper, 1985; Tarmizi & Sweller, 1988; Ward & Sweller, 1990) to create guidelines for complete cognitively driven instructional packages. As mentioned in the introduction, a heavier than normal use of worked examples has been shown to be very effective (Cooper & Sweller, 1987; Sweller & Cooper, 1985).

In technical areas, complete instructional packages consist normally of three parts. The first part consists of introductory explanatory instructions, similar to those used in the current series of experiments. The second part usually includes one or two worked examples designed to demonstrate the new material. The third part normally consists of a large number of problems or exercises. The current results, along with the previous findings, have clear and direct implications for each of these components of instruction:

1. Conventional introductory instructions that consist of multiple sources of information that need to be mentally integrated in order to be understood should be restructured into integrated formats. Sometimes integration may be impossible, but frequently it can be achieved relatively easily. If sources of information cannot be restricted to a single entity, they should be integrated into as small a number of units as possible. If conventional instructions consist of a source of information that is fully intelligible by itself, other related information, whether it be textual or diagrammatic, should be removed to prevent unnecessary attempts at integration.
2. These same rules apply to the structure of worked examples used to demonstrate principles taught during initial instruction.
3. Far more emphasis should be placed on worked examples, rather than conventional problems or exercises, by mixing large numbers of integrated worked examples with conventional problems.



On the evidence of the current and previous empirical work, the implementation of these suggestions should result in substantial benefits.

### ACKNOWLEDGMENTS

The work reported in this article was supported by Grant No. AC9031965 from the Australian Research Council to John Sweller.

The cooperation and support provided by the staff of the New South Wales Department of Education and by Email Ltd. was greatly appreciated. We extend our sincere thanks to Email's training staff: Brian Jones, Richard Winter, John Harley, and Jim Jarrick.

### REFERENCES

- Ayres, P., & Sweller, J. (1990). Locus of difficulty in multi-stage mathematics problems. *American Journal of Psychology*, *103*, 167-193.
- Chi, M., Bassok, M., Lewis, M., Reimann, P., & Glaser, R. (1989). Self-explanations: How students study and use examples in problem solving. *Cognitive Science*, *13*, 145-182.
- Cooper, G., & Sweller, J. (1987). The effects of schema acquisition and rule automation on mathematical problem-solving transfer. *Journal of Educational Psychology*, *79*, 347-362.
- Larkin, J., & Simon, H. (1987). Why a diagram is (sometimes) worth ten thousand words. *Cognitive Science*, *11*, 65-99.
- Owen, E., & Sweller, J. (1985). What do students learn while solving mathematics problems. *Journal of Educational Psychology*, *77*, 272-284.
- Sweller, J. (1988). Cognitive load during problem solving: Effects on learning. *Cognitive Science*, *12*, 257-285.
- Sweller, J. (1989). Cognitive technology: Some procedures for facilitating learning and problem solving in mathematics and science. *Journal of Educational Psychology*, *81*, 457-466.
- Sweller, J., Chandler, P., Tierney, P., & Cooper, M. (1990). Cognitive load and selective attention as factors in the structuring of technical material. *Journal of Experimental Psychology: General*, *119*, 176-192.
- Sweller, J., & Cooper, G. A. (1985). The use of worked examples as a substitute for problem solving in learning algebra. *Cognition and Instruction*, *2*, 59-89.
- Sweller, J., Mawer, R., & Howe, W. (1982). Consequences of history-cued and means-ends strategies in problem solving. *American Journal of Psychology*, *95*, 455-483.
- Sweller, J., Mawer, R., & Ward, M. (1983). Development of expertise in mathematical problem solving. *Journal of Experimental Psychology: General*, *112*, 639-661.
- Tarmizi, R., & Sweller, J. (1988). Guidance during mathematical problem solving. *Journal of Educational Psychology*, *80*, 424-436.
- Ward, M., & Sweller, J. (1990). Structuring effective worked examples. *Cognition and Instruction*, *7*, 1-39.
- Zhu, X., & Simon, H. (1987). Learning mathematics from examples and by doing. *Cognition and Instruction*, *4*, 137-166.