



# IJRASET

International Journal For Research in  
Applied Science and Engineering Technology



---

# INTERNATIONAL JOURNAL FOR RESEARCH

IN APPLIED SCIENCE & ENGINEERING TECHNOLOGY

---

**Volume: 10    Issue: VI    Month of publication: June 2022**

**DOI: <https://doi.org/10.22214/ijraset.2022.44170>**

**[www.ijraset.com](http://www.ijraset.com)**

**Call:  08813907089**

**E-mail ID: [ijraset@gmail.com](mailto:ijraset@gmail.com)**

# Design and Construction of Vertical Axis Wind Turbine Blades

Himanshu Meena<sup>1</sup>, Jashwant Kumar<sup>2</sup>

<sup>1,2</sup>B.tech Scholar, Department of Mechanical Engineering, Arya Institute of Engg. & Technology, Rajasthan, India

**Abstract:** This study aims to check the Vertical Axis Wind Turbines blades and their different types and their feasibility. Increase in energy demand results in need of clean energy like wind energy.

This project is done to design and construct the vertical axis wind turbine blade for small scale usage. The vertical axis wind turbine is having axis of rotation vertically and that's why yaw motor is eliminated.

The demand of renewable energy sources is increasing day by day as the fossil fuel is limited and will end one day as well as it has adverse effect in environment and which leads to green house effect, etc

## I. INTRODUCTION

Fossil fuel is the main contributor of the adverse effect of environment and oil and gas reserves are finite, so world is looking for sustainable alternative energy source for the global energy demand. [1].

Wind energy is the most prominent option for the power generation in recent time and for commercial use . Since the researches is done majorly on horizontal axis wind turbine because it has large power output and greater efficiency as compared to vertical axis wind turbine. But vertical axis wind turbine have number of advantages against horizontal axis wind turbine.

Vertical axis wind turbine can be used for small scale and it can be installed in every building.

The installed wind potential of the world according to world wind energy association is given in the graph.

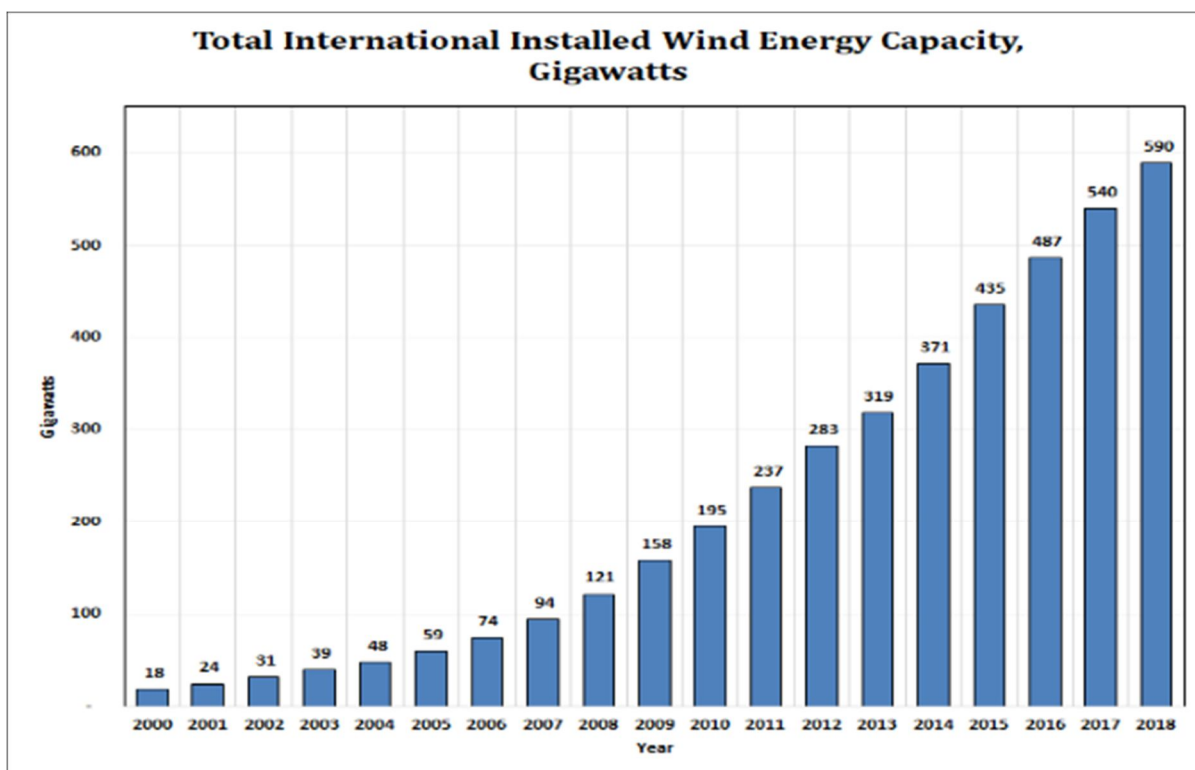

Figure:- Global wind energy capacity growth. Data source: The Wind Power Statistics [4].

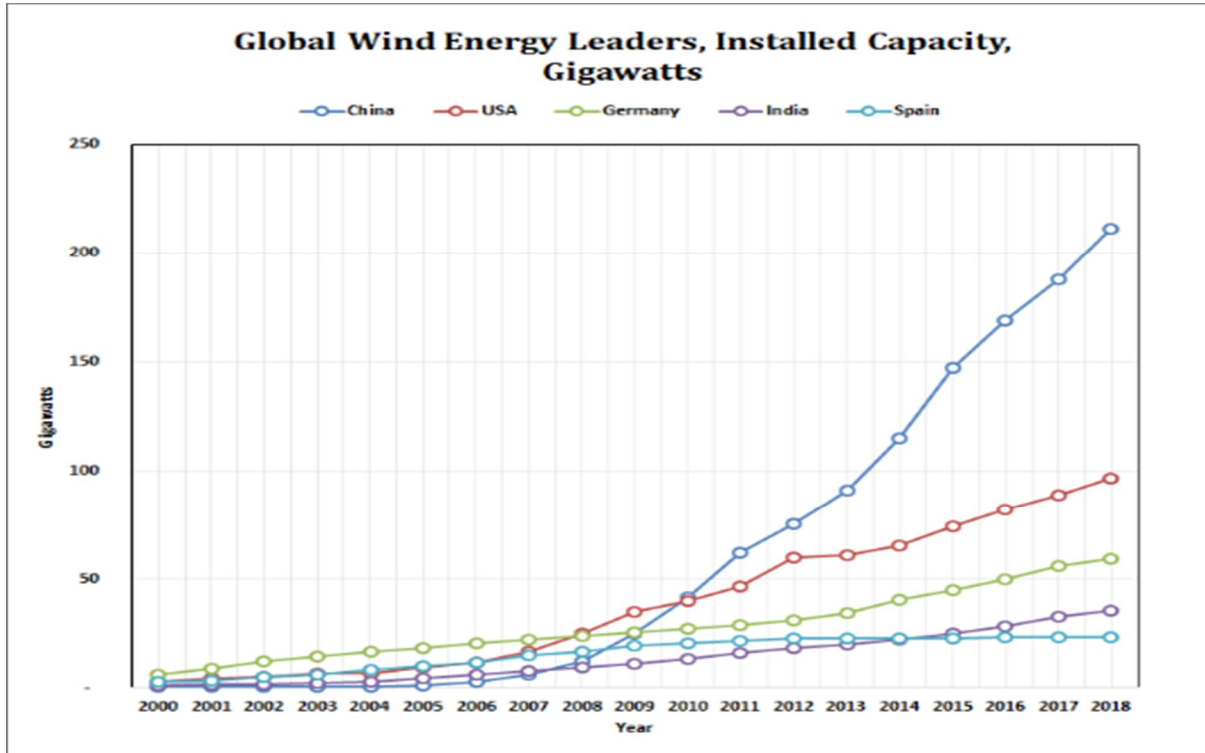

Figure :- Country level wind energy capacity growth. Data source: The Wind Power, Statistics [4]

### II. TYPES OF WIND TURBINE

The Vertical axis wind turbine have two different types of set ups, Darrieus and Savonius. Savonius type having half cylindrical blades generating drag difference and Darrieus type uses airfoil shape blades which creates pressure difference which generates lift force, which turns the main shaft and power is generates.[2].

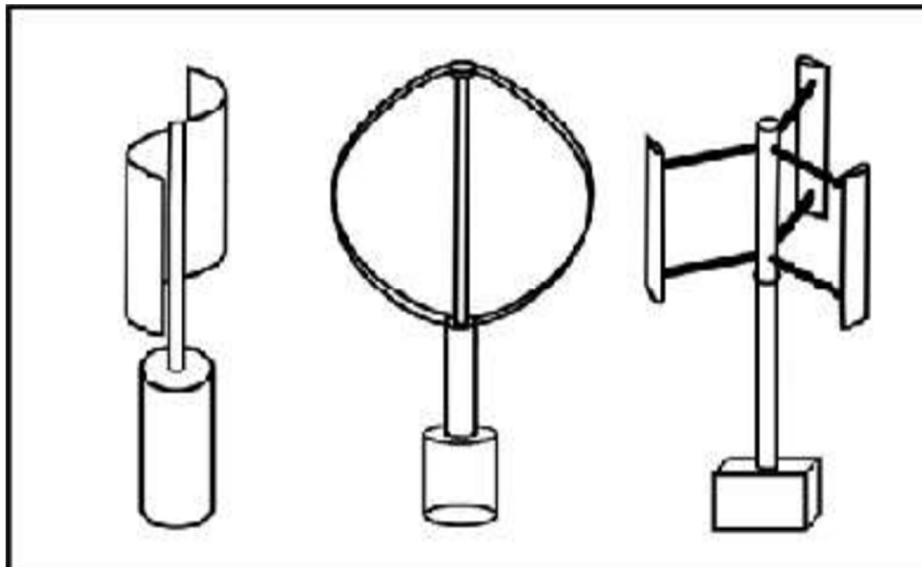

Fig:- Basic VAWT configuration [1]

### III. BENEFITS OF VAWT

The vertical axis wind turbine runs in all direction but horizontal axis wind turbine is uni-directional. Demerit of vertical axis wind turbine is it has lower efficiency but to overcome it cluasturing is done.[3].

Vertical axis wind turbine do not require any yaw motor arrangement but we require in horizontal axis wind turbine.

#### IV. DESIGNED VERTICAL AXIS WIND TURBINE

The blade of the designed vertical axis wind turbine is taken to be 10 inches wide and the height of the blade is 31 inches. All five blades are attached over a shaft which rotates and delivers the power to the dynamo, this dynamo generates the power. An experimental modal is being created of darrieus type and being investigated the results are obtained. The turbine test is satisfactory and output voltage (12v max) is obtained and the charge is stored in a battery setup and after inverter the result is obtained and the capacity is 100 watts.



Fig:- Vertical axis wind turbine

#### V. FUTURE WORK

Current study of planetary turbine is undergoing process and the the efficiencies of the turbine can be increased.

#### VI. CONCLUSION

Today maximum machines are designed for reducing greenhouse emission which is cause of climate change.

The dominance of non-renewable sources of energy is being reduced.

The renewable source of energy provide clean energy by innovative ideas in technology. It not only deduce the electricity bill but also reduces the adverse effect of pollution on environment and also reduces effect on ozone layer. The vertical axis wind turbine is only used for small power output and is designed to meet environmental pollution .

So the wind turbine is used to minimize the dependency over the non-renewable sources of energy.

#### REFERENCES

- [1] Hand B, Kelly G, Cashman A. Aerodynamic design and performance parameters of a lift-type vertical axis wind turbine: A comprehensive review. *Renew Sustain Energy Rev* 2021;139(2021):110699.
- [2] Möllerström E, et al. A historical review of vertical axis wind turbines rate 100kW and above. *Renew Sustain Energy Rev* 2019;105(1):1–13.
- [3] Barnes A, Hughes B. Determining the impact of VAWT farm configurations on power output. *Renew Energy* 2019;143(1):1111–20.
- [4] The Wind Power. Wind energy Market Intelligence, Statistics. Available online: <https://www.thewindpower.net/index.php> (accecced on 16 July 2020)



10.22214/IJRASET



45.98



IMPACT FACTOR:  
7.129



IMPACT FACTOR:  
7.429



# INTERNATIONAL JOURNAL FOR RESEARCH

IN APPLIED SCIENCE & ENGINEERING TECHNOLOGY

Call : 08813907089  (24\*7 Support on Whatsapp)