

MICROSTRIP GAS CHAMBERS ON IMPLANTED SUBSTRATES

A. Pallarès, J.M. Brom, R. Fang, J.C. Fontaine, W. Geist, T. Kachelhoffer, J.M. Levy, V. Mack.

Technical staff : S. Barthe*, A.M. Bergdolt, J. Cailleret, E. Christophel, J. Coffin, H. Eberlé, J.P. Schunck*, M.H. Sigward.

Centre de Recherches Nucléaires - Université Louis Pasteur - Université de Haute Alsace,
23, rue du Loess, BP 28, 67037 Strasbourg Cedex 2.

*Laboratoire PHASE (UPR 292 du CNRS),
23, rue du Loess, BP 28, 67037 Strasbourg Cedex 2.

CERN LIBRARIES, GENEVA



SCAN-9509043

Abstract

Six 8536

We have studied the performance of several Microstrip Gas Chambers (MSGC) prototypes made on standard Desag D263 boron implanted glass. The purpose of the implantation is to reduce the surface resistance. The long term stability of this implantation has been measured under applied bias voltage. Comparative tests have been carried out on prototypes made on implanted and non-implanted detectors under electron (^{90}Sr) and X-ray (8 keV) irradiation. The total dose was approximately 7 mC/cm .

1. INTRODUCTION

Microstrip Gas Chambers (MSGC) are a recent detector development in particle physics. They derive directly from the multiwire proportional chamber (MWPC) concept initiated by G. Charpak [1,2]. In a MWPC a plane of anode wires lies between two cathode planes. Each anode wire acts as an individual proportional counter, thereby allowing spatial resolution, of the order of half the wire spacing, of about 1 mm. The cathode drift planes define the drift region for primary electrons. High voltage applied to the cathode wires defines an electrical field that induces the electron avalanche and leads to an observable signal on the anode wires via the avalanche formation.

However, the spatial resolution of MWPC is limited for mechanical reasons. MSGC improve this resolution by reducing pitch and wire dimensions. These detectors are made from thin metallic strips (alternately anodes and cathodes) engraved on a dielectric substrate by means of standard microelectronic techniques. A cathode plane at a few millimeters above the substrate defines the electric drift field.

The dielectric support of the MSGC (glass, plastic, etc.) was supposed to have mainly a mechanical role with negligible influence on the detector performance. But in the early years of MSGC, experience showed gain instabilities and variations probably due to charge accumulation at the surface of the substrate. These effects modify locally the electric field. For glasses with electronic conductivity, the gain reduction is small or inexistent [3,4]. Hence the substrate resistivity is of primary importance.

Several methods were used to control the substrate's electrical resistance : manufacture of special low resistance glass (the so-called Moscow glass developed by the BIP-Novosibirsk), application of passivation layers [5,6] and ion implantation [7,8]. The latter method, namely boron implantation of standard high resistivity Schott D263 glass is chosen here.

2. EXPERIMENTAL PROCEDURES

All detectors used for the following measurements were fully homemade. They have been manufactured by the PHASE laboratory in collaboration with the Centre de Recherches Nucléaires of the CNRS Strasbourg. This facilitates knowledge and control of all parameters during the detector fabrication (cleaning, metallization, etching, etc.). Figure 1 shows such a typical laboratory-made MSGC.

2.1. ION IMPLANTATION

Ion implantation is a well-known process that modifies surface properties. It is a precise and reproducible method in which one has an easy control of the implantation energy, dose and density profile of the implanted element.

Standard D263 glasses were implanted (before or after detector fabrication) with boron at an energy of 18 keV and at a dose of 10^{15} ions/cm². Under these conditions, the boron is typically concentrated in a glass surface layer about 1000 Å thick.

2.2. MEASUREMENTS OF SURFACE RESISTANCE

All measurements of surface resistance were made on bare glass plates using a three electrode arrangement (standard insulator resistance measurement method ASTM D257) shown schematically in figure 2. A known potential (200 V in the present case) is applied to the sample and the resulting current is measured with a picoammeter. The guarding of electrode 3 plays an important role : it minimizes errors due to bulk resistance while making surface resistance measurements.

When a potential difference is applied to the sample, the resulting current decreases asymptotically towards a limiting value. This decrease of current with time is due to dielectric absorption (interfacial polarization, volume charge, etc.) and the sweep of mobile ions to the electrodes. Thus it is necessary to specify the time of electrification, which is about 1000 min in our standard measurements. This amount of time is required to reach a stable dielectric state.

The measured surface resistance is largely dependent on the contamination that happens to be on the glass surface. However the permittivity of the glass influences deposition of contaminants and its surface characteristics affect the conductance of the contaminants. Surface resistance also depends on the working atmosphere (humidity, temperature and gas). In summary, surface resistance measurements are more qualitative than quantitative. Absolute values may not be accurate but relative ones remain comparable. Measurements are only comparable when the procedure used is identical (applied voltage, electrification time, atmosphere, etc.).

2.2.1. Effects of ion implantation

For Schott D263 glass, surface resistance exceeded $5 \cdot 10^{15} \Omega$ before implantation and was about $2 \cdot 10^{14} \Omega$ after at a boron dose of 10^{15} ions/cm². It is obvious that one is able to control glass surface resistance by implantation dose. As an example, figure 3 shows a typical decrease of glass surface resistance with increasing ion implantation dose for iron ions (at an energy of 150 keV on Corning 7059 glass).

2.2.2. Resistance stability

Doping by ion implantation consists of introducing ions in a stable glass matrix. However the implanted elements may continue to migrate under external forces like electrical fields. This migration can lead to important modifications of the surface resistance with time. We have checked the stability of the surface resistance under bias voltage over a period of days. The glass polarization was always kept at 200 V. Figure 4 shows that after a short stabilization period, the surface resistance remains constant with time (within the accuracy limits).

3. EFFECT OF ION IMPLANTATION ON DETECTOR PERFORMANCE

We observed a significant improvement of the performance of implanted detectors compared to non-implanted ones.

The gain evolution of implanted and non-implanted detectors as a function of ^{90}Sr (e^- , $E_{\text{max}}=2.282$ MeV; 10 mCi) irradiation dose is shown in figure 5. In both cases, a gain reduction under irradiation is observed. However, the gain drop of the implanted detector is clearly smaller compared to the non-implanted one (10% after 0.1 mC/cm for the implanted one compared to 60% for the non-implanted one).

Figure 6 shows the gain stability of an implanted detector irradiated with 8 keV X-ray at a rate of 10^6 mm $^{-2}$ ·s $^{-1}$. After a small decrease (about 5%) at the beginning of the irradiation, the gain remains stable. The difference compared to ^{90}Sr irradiation is supposed to be due to the gas system which is different for each type of irradiation and less clean in ^{90}Sr irradiation case. It has also been shown that the loss of gain may be strongly dependent on the irradiation rate [9].

4. CONCLUSIONS

Ion implantation was shown to improve the gain stability of MSGC made on standard high resistivity glass exposed to high radiation rates.

To obtain surface resistance reduction, previous work shows that the choice of the implanted element, if stable in the glass matrix, may be without importance [10]. The fundamental mechanisms by which ion implantation decreases surface resistance are still not fully understood. Ion implantation causes alkali depletion near the glass surface such that ionic conduction may be avoided [11]. It also creates paramagnetic defects (which may be charged) in the glass structure [12]. Combination of these two effects may provide an adequate conduction mechanism.

REFERENCES

- [1] G. Charpak, *Ann. Rev. Nucl. Sci.* 20 (1970) 195.
- [2] G. Charpak, D. Rahm, H. Steiner, *Nucl. Instr. and Meth.* 80 (1970) 13.
- [3] G. Minakov, Y. Pestov, V. Prokopenko, L. Shekhtman, *Nucl. Instr. and Meth.* A326 (1993) 566.
- [4] R. Bouclier, G. Million, L. Ropelewski, F. Sauli, Y. Pestov, L. Shekhtman, *Nucl. Instr. and Meth.* A332 (1993) 100.
- [5] S. Brons, W. Bruckner, M. Heidrich, I. Konorov, S. Paul, *Nucl. Instr. and Meth.* A342 (1994) 411.
- [6] S. Salomon, J. Armitage, G. Chapman, M. Dixit, J. Dubeau, W. Faszer, L. Hamel, G. Oakham, *Nucl. Instr. and Meth.* A348 (1994) 313.
- [7] J. Van Der Marel, A. Van Den Bogaard, C. Van Eijk, R. Hollander, W. Okx, P. Sarro, *Nucl. Instr. and Meth.* A348 (1994) 383.
- [8] M. Dixit, F. Oakham, J. Armitage, J. Dubeau, D. Karlen, G. Stuart, S. Taylor, I. Shipsey, E. Johnson, A. Greenwald, *Nucl. Instr. and Meth.* A348 (1994) 365.
- [9] F. Sauli, this conference.
- [10] A. Pallarès, S. Barthe, A.M. Bergdolt R. Blaes, J.M. Brom, J. Cailleret, E. Christophel, J. Coffin, H. Eberlé, R. Fang, J.C. Fontaine., W. Geist, T. Kachelhoffer, H. Kettunen, V. Mack, A. Michalon, J.L. Riester, A. Romero, J.P. Schunck, M.H. Sigward, R. Stuck, C. Voltolini, CRN report 93-64 (1993).
- [11] O. Puglisi, G. Marletta, A. Torrisi, *J. Non-Cryst. Solids* 83 (1986)344.
- [12] G.W. Arnold, *J. Non-Cryst. Solids* 179 (1994) 288.

FIGURE CAPTIONS

- Figure 1 : Laboratory-made MSGC (glass surface $2.6 \cdot 2.6 \text{ cm}^2$, $200 \text{ }\mu\text{m}$ pitch, anode and cathode respectively $9 \text{ }\mu\text{m}$ and $70 \text{ }\mu\text{m}$ width) .
- Figure 2 : The three electrode arrangement for insulator resistance measurements.
- Figure 3 : Typical evolution of surface resistance as a function of implanted dose (the solid line is only to guide the eye).
- Figure 4 : Evolution of the surface resistance as a function of time (bias voltage : 200 V , the solid line is only to guide the eye).
- Figure 5 : Variation of gain as a function of electron irradiation dose (^{90}Sr , 10 mCi).
- Figure 6 : Variation of gain as a function of X-ray irradiation dose (8 keV , $10^6 \text{ mm}^2 \cdot \text{s}^{-1}$).

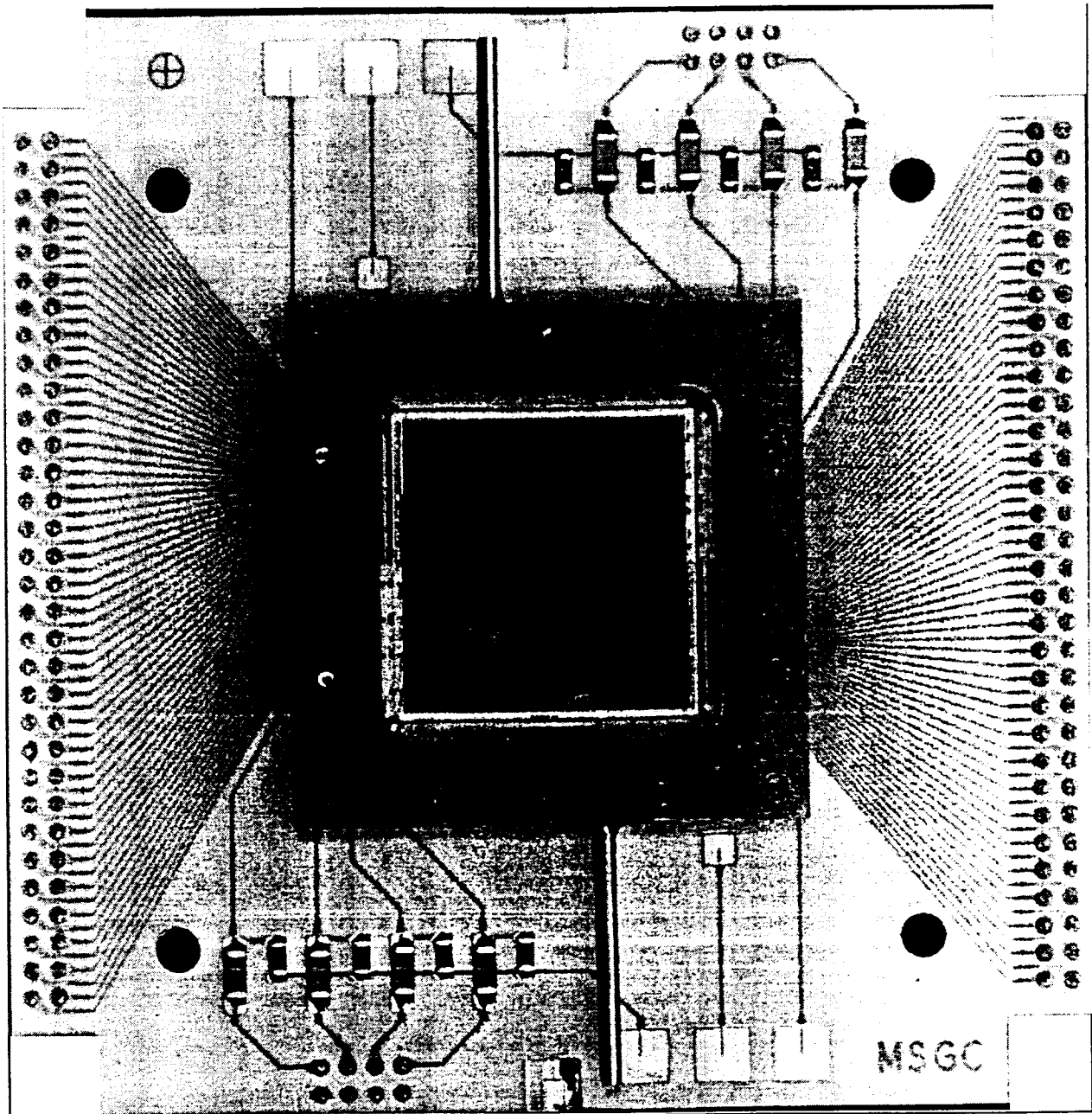

Figure 1

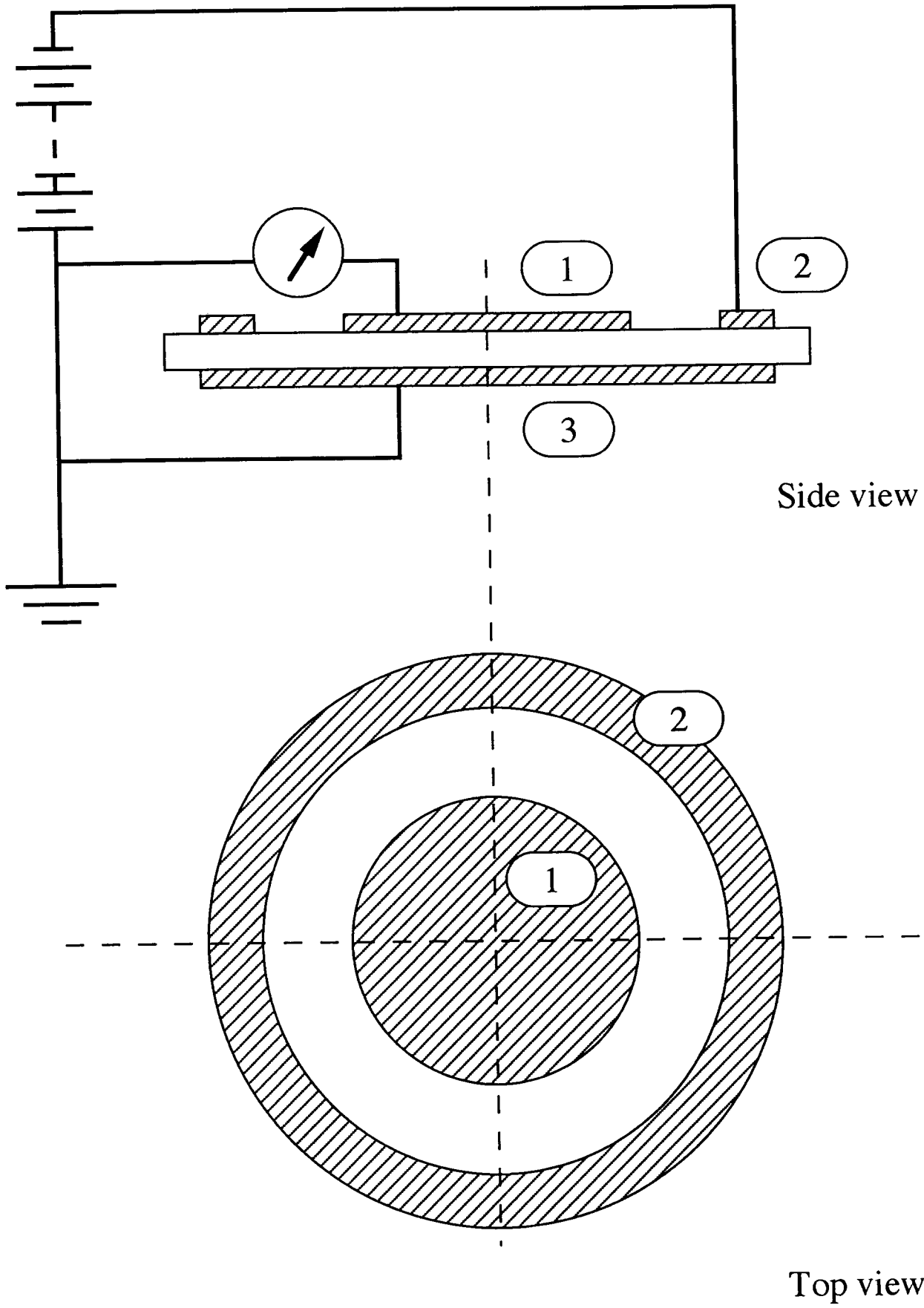

Figure 2

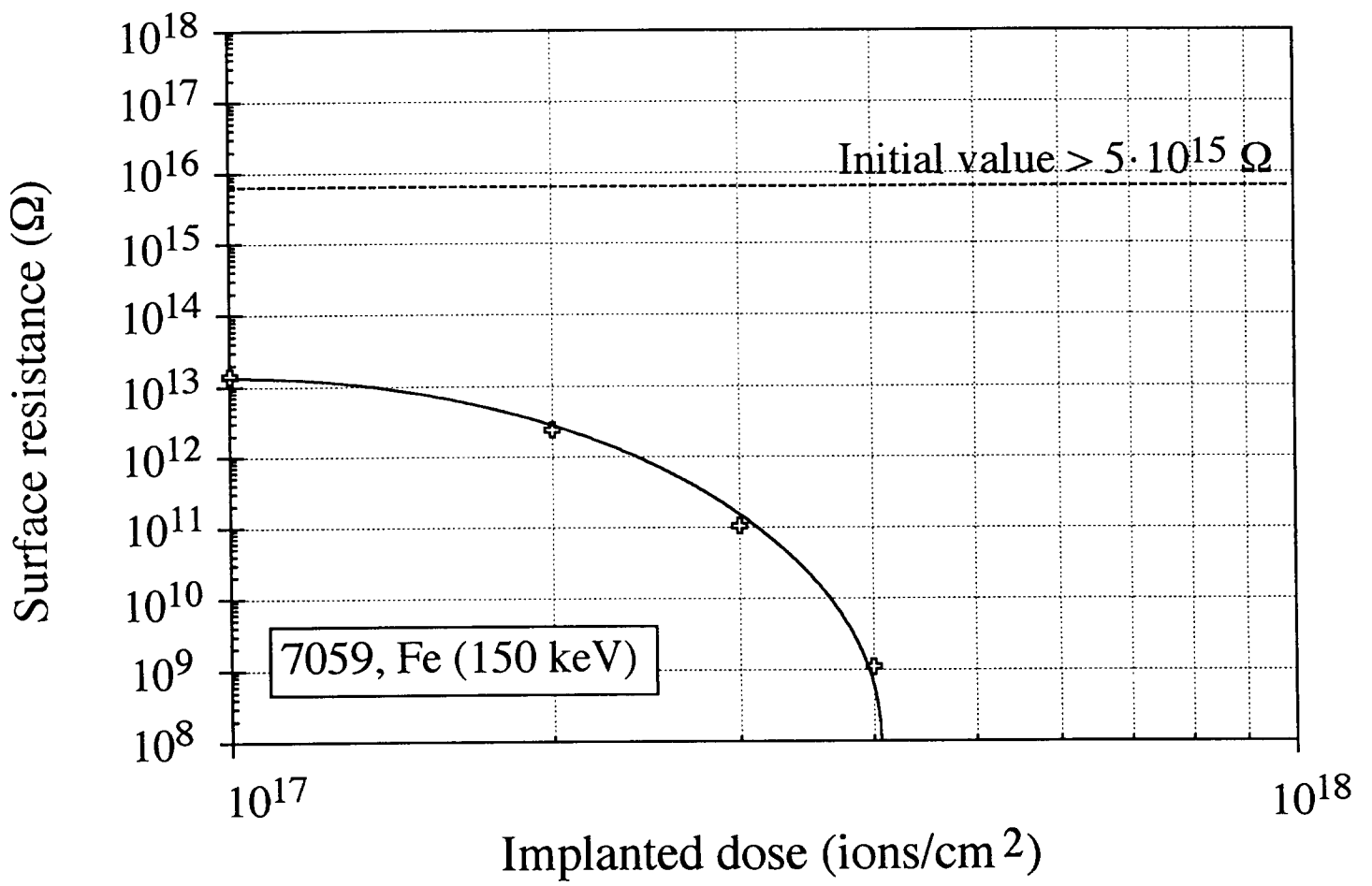

Figure 3

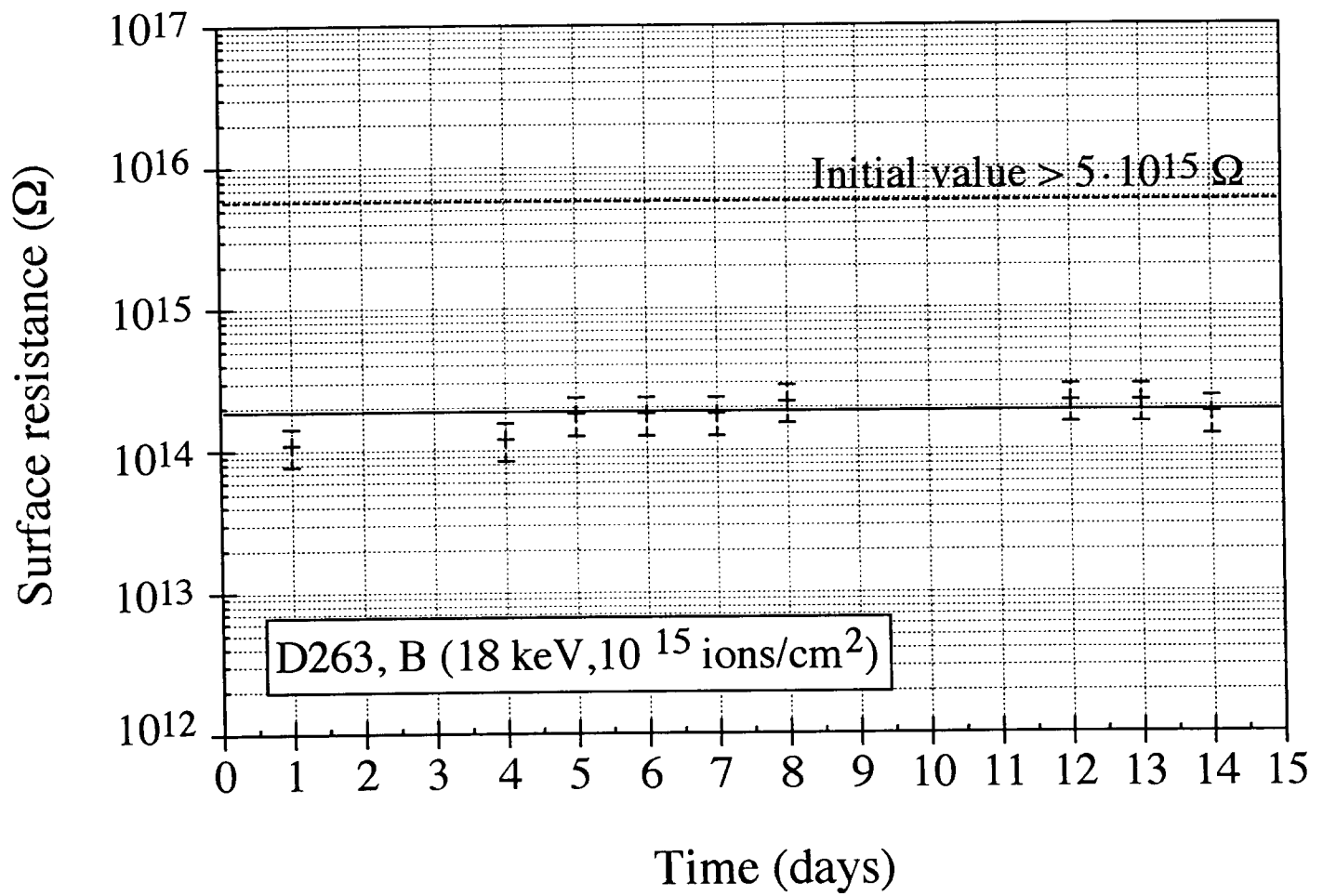

Figure 4

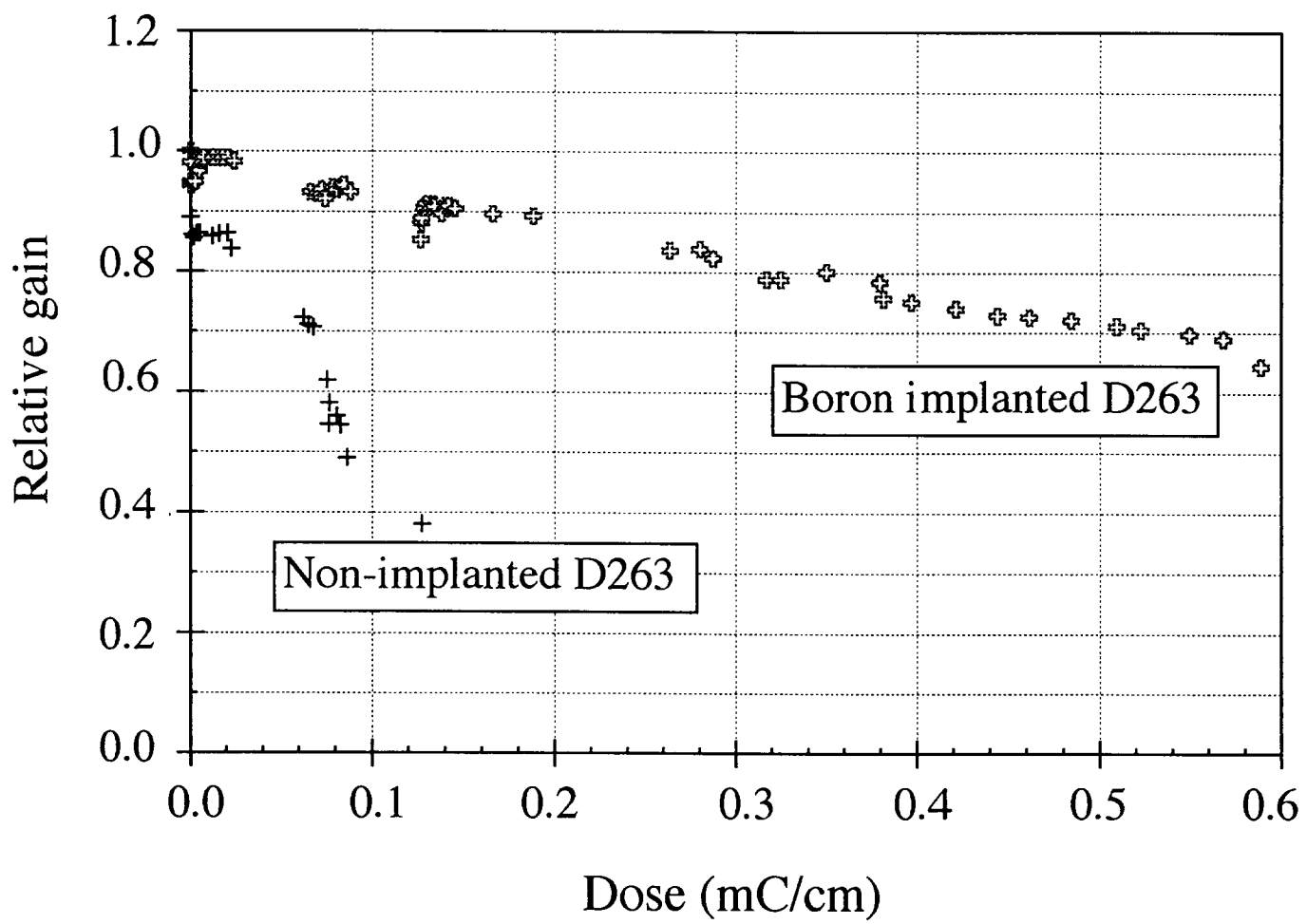

Figure 5

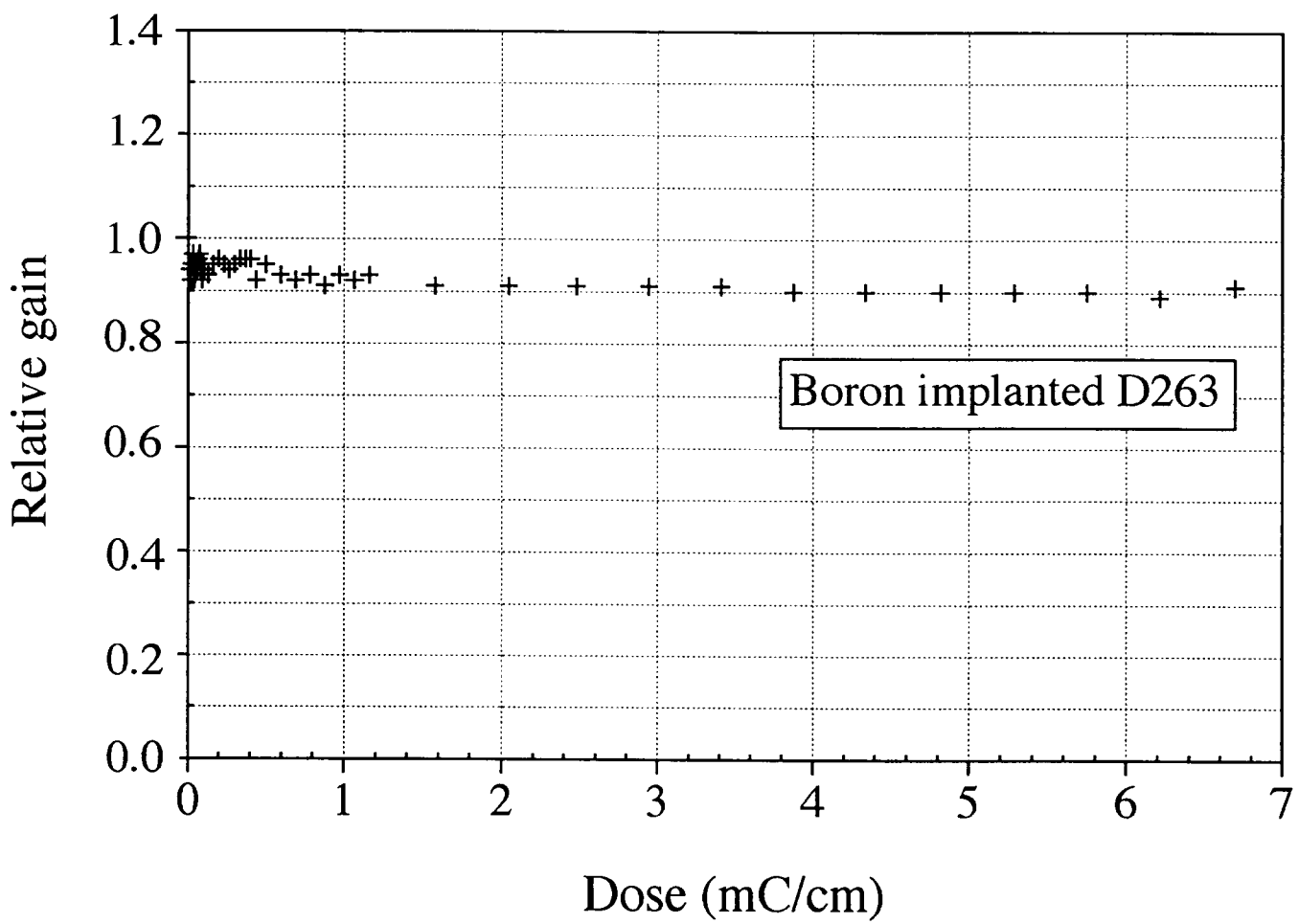

Figure 6