



Contents lists available at ScienceDirect

Transportation Research Part C

journal homepage: www.elsevier.com/locate/trc

Review

Survey of the operation and system study on wireless charging electric vehicle systems

Young Jae Jang

Department of Industrial and Systems Engineering, KAIST (Korea Advanced Institute of Science and Technology), Republic of Korea



ARTICLE INFO

Keywords:

Wireless charging
Electric vehicles
Transportation systems
Transportation planning
Research survey

ABSTRACT

This survey investigates the state-of-the-art in operations and systems-related studies of wireless charging electric vehicles (EVs). The wireless charging EV is one of emerging transportation systems in which the EV's battery is charged via wireless power transfer (WPT) technology. The system makes use of charging infrastructure embedded under the surface of the road that transfers electric power to the vehicle while it is in transit. The survey focuses on studies related to both dynamic and quasi-dynamic types of wireless charging EV – charging while in motion and while temporarily stopped during a trip, respectively. The ability to charge EVs while in transit has raised numerous operations and systems issues that had not been observed in conventional EVs. This paper surveys the current research on such issues, including decisions on the allocation of charging infrastructure; cost and benefit analyses; billing and pricing; and other supporting operations and facilities. This survey consists of three parts. The first provides an orienting review of terminology specific to wireless charging EVs; it also reviews some past and ongoing developments and implementations of wireless charging EVs. The second part surveys the research on the operations and systems issues prompted by wireless charging EVs. The third part proposes future research directions. The goal of the survey is to provide researchers and practitioners with an overview of research trends and to provide a guide to promising future research directions.

1. Introduction

As electric vehicles (EVs) have become increasingly popular as a mainstream transportation solution, opportunities to recharge the vehicle away from home have become a critical issue. *Wireless charging EV* is a type of EV in which charging is done using wireless power transfer (WPT) technology, which does not require any physical contact in the process of transferring electric energy. WPT has been successfully applied for charging various handheld devices, such as medical devices, electronic toothbrushes, and smartphones. It has also been widely used for automated material handling systems in semiconductor fabrication and flat-panel display production lines (Covic and Boys, 2013). Wireless charging technology was first commercialized for automobiles to eliminate the conventional charging of 'plug-in' EVs – charged by connecting a wired cable from a charger to the vehicle. The first wireless charging technology to be deployed was *stationary*, the system having been designed to charge EVs in garages or public parking spaces, when the vehicle is not operating for an extended period. Because a physical connection is not required, there has been major interest in the possibility of charging EVs while they are in transit. Charging an EV while in motion is called *dynamic wireless charging*. A typical dynamic wireless charging EV is a pure, battery-only EV that takes its electrical charge in motion, remotely, from a wireless charger installed underneath the road surface. Roads capable of supplying electric power to wireless charging EVs are called *electrified roads* or *charging*

E-mail address: yjang@kaist.ac.kr.

<https://doi.org/10.1016/j.trc.2018.04.006>

Received 7 November 2017; Received in revised form 20 March 2018; Accepted 9 April 2018
Available online 23 April 2018

0968-090X/© 2018 The Author(s). Published by Elsevier Ltd. This is an open access article under the CC BY license (<http://creativecommons.org/licenses/by/4.0/>).

lanes. There is also a third wireless charging category, *quasi-dynamic wireless charging*, in which the charging takes place when the EV decelerates to or accelerates from a resting position.

For both dynamic and quasi-dynamic wireless charging, charging can be done while the EV is in transit. These new charging mechanisms extend the operational range of EVs with both rapid boost charging during brief station stops and dynamic or “on the fly” charging opportunities.

Stationary wireless charging makes the charging process safer and more convenient (Cirimele et al., 2016). However, in terms of charging time, frequency, the operation of the vehicle, and charging station allocation, stationary charging is not significantly different from conventional plug-in conductive charging. In contrast, dynamic and quasi-dynamic wireless charging enable the EVs battery to be charged while in operation. This capability has raised new operations and infrastructural design issues that had never been raised for conventional plug-in EVs. These issues are the focus of this paper. Note that in this paper, references to “wireless charging EV” indicate dynamic and quasi-dynamic wireless charging EVs, if not specified. For the readers interested in the static charging technology, refer to the following work: (Abe et al., 2000; Birrell et al., 2015; Wu et al., 2012; Foley et al., 2010). It should also be stated that although the term wireless charging EV suggests a single vehicle unit, it should be understood as a system comprised of EVs and the charging infrastructure. Further terminological and categorical distinctions are discussed in subsequent sections.

The first commercial dynamic wireless charging electric vehicle, the On-Line Electric Vehicle (OLEVTM), was deployed in 2009 by the Korea Advanced Institute of Science and Technology (KAIST), South Korea, and received ample media attention (Miller et al., 2015). A significant body of literature has been published specifically on the technical engineering challenges posed by wireless charging EVs. Some topics of the most highly cited papers include charging topology for wireless charging (Yilmaz and Krein, 2013); electric vehicle design and technologies (Li and Mi, 2015; Wu et al., 2011; Covic and Boys, 2013); hardware and systems design (Kim et al., 2013; Shin et al., 2014); road construction and pavement issues (Chen et al., 2015); power flow control (Miller et al., 2015); and efficiency optimization (Imura and Hori, 2011).

By contrast, research on *operations and systems* issues is still nascent. Definitions of operations and systems challenges remain somewhat broad. In this paper, however, they refer specifically to modeling, analysis, and methods that can be leveraged to support and enhance effective and efficient operations of wireless charging-based transportation systems. The term *system* is used explicitly because the research challenges are not limited to just vehicular components but also include: supporting facilities such as charging infrastructure; information handling in intelligent transportation systems (ITS); integration with smart grids; economic analyses for the pricing of charging; and other related managerial strategies and tactics.

Studies that deal with these issues tend to address the following questions:

- What are the long-term and short-term economic benefits of wireless charging EVs relative to other existing transportation systems?
- How much charging infrastructure should be allocated to maximize the economic benefit of this emerging transportation system?
- What are the critical design parameters for wireless charging EVs, given transportation requirements, and how do we determine them?
- How can policymakers design operational policies, rules, and regulations for new transportation systems?
- How can we design information systems to optimize the systems benefits?
- How would this new transportation system affect existing traffic and how should this be analyzed?
- What are the environmental benefits of wireless charging EV over conventional transportation systems in terms of sustainability?

Operations and systems research for wireless charging EVs is a multidisciplinary research domain, the success of which depends on integrated efforts. There is little doubt that academic research on operations and systems perspectives is critical, particularly in the current stage of the technology’s development. WPT technology, the key enabler of the wireless charging EV, has been improving rapidly. As mentioned previously, several commercialized WPT systems have already been made available. Given that the technology has reached this phase so rapidly, systematic investigations of its operations and systems implications for wireless charging EVs are needed. Several reasons can be given for why such an investigation is appropriately timed.

- First, there is high demand for surveys from government sectors, particularly policymakers and regulators, in addressing the operations and systems challenges posed by wireless charging EVs, especially for understanding the state-of-the-art. For example, in South Korea, one of the first countries where wireless charging EVs have been commercialized for public transportation, traffic and transportation administration agencies have funded research on analyzing the economic value of such systems. Similarly, the Transport Research Laboratory in the UK investigated the feasibility of dynamic WPT for EVs and published *Feasibility study: powering electric vehicles on England’s major roads* (Highway England, 2015) on behalf of Highways England, the government agency in charge of operating, maintaining, and improving England’s motorways and major roads. The European Union has also launched FABRIC (feasibility analysis and development of on-road charging solutions for future electric vehicles) a project to investigate the technological feasibility, economic viability, and socio-environmental sustainability of dynamic on-road charging of EVs (de Blas, 2017). In 2012, the US Department of Transportation (DOT) recognized the emergence of WPT charging of vehicles and the need to understand the implications of in-motion charging of vehicles on highways (Miller et al., 2015). This research considered what approaches might be adopted to best analyze the economic benefits of the technology and served as a guideline for electricity pricing. International scientific and technical communities, such as the SAE and IEEE, have also created working groups to draft recommendations for standardizing parts and components of the wireless charging system and to write

guidelines for system operations (Brecher and Arthur, 2014; Miller et al., 2015). This study will provide a comprehensive overview of the current research to provide policymakers and regulators state-of-the-art information about wireless charging EVs, as developed among experts in the academic community.

- Second, a system-wide understanding of the technology is needed to ensure that it moves in the right direction. Many disciplines are currently pursuing research on the development of wireless charging EVs. Progress and innovation are driven by each disciplines state-of-the-art knowledge and eventually will result in individually optimized solutions. However, because different disciplines sometimes fail to communicate with one another, it cannot be guaranteed that the summation of these solutions will result in an optimized solution as a whole. Hardware development and operations design should be considered as a whole at the earliest stage in the emerging technologies development cycle.
- Third, this survey will also provide a guide for academic researchers, orienting them to new research directions outside their own discipline. Research on the operations and systems challenges posed by WPT and wireless charging EVs has considerable value. By presenting the state-of-art of the current research, researchers will better understand the various components and dimensions to the new transportation system and be better able to identify promising new research approaches.

The goals of the survey are clear. It summarizes the state-of-the-art in ongoing research on wireless charging EVs, promoting a systems view of the technology to foster interdisciplinary dialogue. It also organizes and categorizes the extant literature so that regulators, policymakers, and transportation engineers can orient to specific research areas within the broader literature. It concludes by identifying promising new directions for future study.

The electrical and mechanical engineer literatures already include a limited number of literature reviews on wireless charging EVs. Some of the previous survey work addresses the following issues:

- Chen et al. (2015) provides a historical overview of the technological developments required for the electrification of roads. This is organized according to various aspects of electrified road construction, such as structural design, pavement type, maintenance issues, and performance measures.
- Gil and Taiber (2014) presents a literature review of recent advancements in stationary and dynamic WPT used for EV charging. This article addresses power limitations, electromagnetic interference regulations, communication issues, and inter-operability to identify technological and infrastructural barriers to transitioning from stationary to dynamic wireless charging.
- Brecher and Arthur (2014) provides a status review of emerging and existing WPT technologies that can be applied to electric bus and rail transit. The WPT technology options discussed, especially inductive power transfer, enable rapid in-station or opportunity (boost) dynamic recharging of electric bus batteries for range extension.
- Similar work Cirimele et al. (2016) presents an overview of the state-of-the-art in current research and industrial projects. Particular attention is devoted to describing a prototypal system for dynamic inductive power transmission, the goal of which is to extend battery range by fast partial recharging as the vehicle is in transit.
- Another similar paper Foote and Onar (2017) reviews current high-power WPT systems and describes the passive elements, devices, subsystems, and techniques that have been developed to achieve high-power levels.

Each of these surveys contains a brief discussion of WPT, the state-of-the-art in deployments and projects, and an overview of issues generally expected to affect the spreading of the technology, to provide general introductions to the technology. None specifically address the operations and systems challenges posed by wireless charging EVs, which suggests a major gap in the literature.

The paper is organized as follows. Section 2 provides a review of the terms and definitions found in existing studies on wireless charging EVs. This section also describes current developments and progress in wireless charging EVs. Section 3 reviews the state-of-the-art of the research. It first describes how the perspectives upon which the section is organized and then proceeds to review the literature based on these perspectives. Section 4 proposes new directions for future research, and the last section concludes the paper.

2. Terms, definitions, technology development for wireless charging EV

This section provides a summary of common terms and definitions for wireless charging EV, a brief introduction to wireless EV configurations, and an overview of the current development and deployment of wireless charging EV systems. Because this emerging transportation is still new to transportation researchers and engineers, and the technology is rapidly evolving, several terms and definitions have not been standardized, nor have related research issues been well defined. For these reasons, this section will provide clear definitions for terms that will be used in subsequent sections.

The introduction to wireless EV configurations has two purposes. First, it will orient the reader to terminologies for the already-standard components of wireless charging EVs, and second, it discusses the boundaries and abstraction level of wireless charging EVs from the perspective of operations and systems issues. The review of major developments in, and uses of, wireless charging EVs is also worthwhile because a significant portion of the extant literature was produced by researchers involved in these projects. Although this discussion will not be exhaustive, it nonetheless introduces the key themes that recur across major projects and indicate the import of operations and systems issues for future work.

2.1. Naming conventions and categorizations

Wireless charging EV or *EV with wireless power transfer* are the most widely used terms to describe the application of WPT

technology to EVs. Variations on these arise occasionally, such as: *in-motion charging* or *charge-on-the-move* (Wu et al., 2011; Nicolaides and Miles, 2015); *contactless charging* or *contactless power transfer* (Chopra and Bauer, 2013); *on-road charging* (Stamati and Bauer, 2013); *electrified road* (Chen et al., 2015); *en-route charging* (Ahmad et al., 2018); and *charging-while-driving* (Chen et al., 2017). Among these variations, *inductive power transfer (IPT) charging* is also one of the most widely used terms. Inductive power transfer originated in the technology used for wireless charging in general. Different WPT technologies are based on two types of electromagnetic field propagation – near-field and far-field transition (Valtchev et al., 2012; Kallialakis and Georgiadis, 2014). Near-field transmissions typically involve application of a magnetic field and inductive techniques to transmit energy across relatively short distances, typically shorter than 1 m. By contrast, far-field electromagnetic transmission methods allow for long-range power transfers and typically involve beamed electromagnetic power, such as lasers, microwave and radio-wave transmissions (Shinohara, 2011). Among the different near-field technologies, inductive coupling or inductive power transfer is the most widely used solution for EVs (Valtchev et al., 2012; Musavi et al., 2012; Chen et al., 2015), and particularly the wireless charging bus, which requires high energy transfer (Valtchev et al., 2012). As a result, the term *Inductive Power Transfer EV* is also widely used to denote wireless charging EVs.

There is no firm agreement on how to categorize wireless charging EVs from the perspective of operations. This survey categorizes wireless charging EV into *stationary*, *quasi-dynamic*, and *dynamic* wireless charging systems. These are defined as follows:

- **Stationary:** The charging is done while the EV is parked and not operational for an extended period at a stationary point, such as a garage or parking lot.
- **Quasi-dynamic:** The charging is carried out when the EV is moving at a low speed while the vehicle decelerates to or accelerates from a resting position.
- **Dynamic:** The charging is done even the EV is in full motion.

These categories are present in some previous work, such as (Cirimele et al., 2016; Foote and Onar, 2017; Jang et al., 2016; Mohamed et al., 2017; Filho and Suh, 2013; Miller et al., 2015; Amditis et al., 2017). Although there are some variations in the terms, such as semi-dynamic or stop-and-go charging for quasi-dynamic, or static for stationary, the categorization basis and definitions remain the same. It should be noted that most of the literature organizes wireless charging into just two categories – stationary and dynamic – and include quasi-dynamic as a subset of dynamic wireless charging. The three-term categorization is used in this survey because quasi-dynamic and dynamic EV systems require different approaches at the systems-level; planning for charging infrastructure, operations scheduling, initial investment calculations, and ITS system design all require different considerations, depending on whether the system will be dynamic or quasi-dynamic. For instance, the frequency of traffic lights or passenger pick-up/drop-off time at bus stops will be critical variables in planning for a quasi-dynamic system, whereas the traffic flow and vehicular speeds will be primary factors for a dynamic wireless charging system. The three-part categorization schema makes the most sense from an operations and systems perspective.

2.2. Components of wireless charging EV

Covic and Boys (2013) defines the components of wireless charging EVs as:

1. the power-supply, which connects the system to the electric grid to receive power;
2. the charging infrastructure or facility, called a power track, which is an elongated track driven by the power supply whose current results in a magnetic field that follows the track;
3. the pickup, which intercepts some of the magnetic field and converts it into controlled electricity; and
4. the load, which is the entity being charged by the electrical power.

Suh and Cho (2017c) dissects the wireless charging system for OLEV into two primary components: the pickup system and power supply system. The pickup system, which is attached to an EV, collects the power while the power supply, installed beneath the road, wirelessly transmits the power. Other studies define the elements similarly (Chen et al., 2015; Xie et al., 2016; Highway England, 2015; Jang et al., 2016; Limb et al., 2016; Choi et al., 2015).

Based on existing studies, a standard conceptual configuration of WPT is proposed as illustrated in Fig. 1. Although WPT has several different technological applications, their conceptual configurations differ little from the standard configuration depicted in the figure, which can also be applied to both dynamic and quasi-dynamic wireless charging EVs. The definitions and functions of the standard configuration are explained as follows:

Power transmitter system is the charging unit that transmits the power by electromagnetic field from the grid. It consists of a **transmitter unit**, the elongated track usually installed under the road that transmits power, and the **power supply unit**, which supplies the power from the grid to the power track.

Pickup system is the component that receives the power from the power transmitter unit and consists of a pickup unit, attached at the bottom surface of the vehicle to receive power, and auxiliary units, such as rectifiers and regulators, which transmit the power from the pickup to the motor and battery.

Notice that the detailed elements in the power supply unit – the power supply, the rectifier, the inverter and controller are

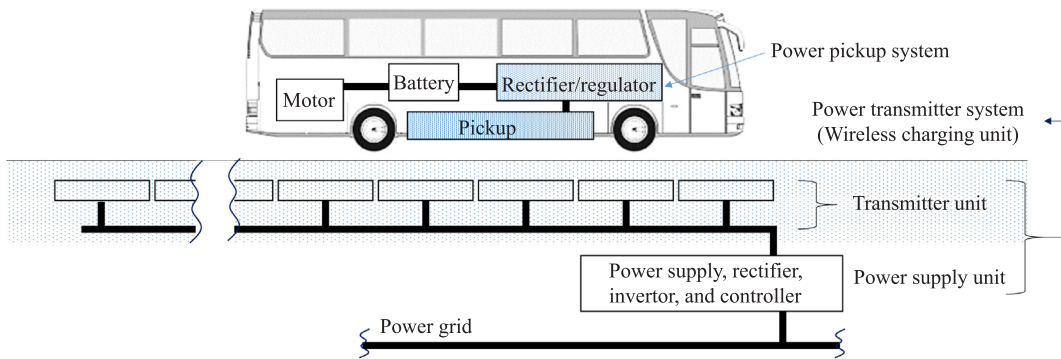

Fig. 1. Standard configuration of wireless charging EV system.

aggregated and lumped together as a single unit. Details of these discrete elements are not usually included in operations and systems studies because some abstraction is typical in such research. This is a sharp contrast with most engineering research on wireless charging EVs, which is concerned with the discrete elements of the power supply and transmitter units or the pick system. Nonetheless, recent work has shown that understanding the conceptual configuration and composition of WPT at the sub-system level can be crucial. Depending on the granularity of the analysis or model, details at the subsystem-level may or may not be needed. For instance, the study by [Chen et al. \(2016\)](#) assumes that the cost of the charging lane is simply proportional to the length of the lane and as such does not require details about the power transmitter system; the model focuses on high-level traffic behavior and as a result details about the configuration of the power transmitter system may not be necessary. By contrast, the models used in [Ko and Jang \(2013\)](#) and other following work did have to account for configurations at the subsystem-level. If the goal is to develop a detailed infrastructural plan for a specific bus route, for example, a detailed cost analysis of the power transmitter system and its internal components, the transmitter and power supply units would indeed be necessary.

In this paper, traffic lanes with a power transmitter system for dynamic charging is called the *charging lane*, and bus stations or temporary stopping points with a power transmitter for quasi-dynamic wireless charging are called *charging stations*. The charging lane and stations are collectively called *charging infrastructures* or *charging facilities*.

2.3. Development and commercialization activities

2.3.1. PATH

Numerous papers, including ([Chen et al., 2015](#); [Palen et al., 2000](#); [Shladover, 2007](#); [Suh and Cho, 2017b](#)), indicate that the Partners for Advanced Transit and Highways (PATH) project, led by researchers at the University of California, Berkeley, developed the first working prototype of the wireless charging EV. A systematic pilot test of dynamic wireless charging EV solutions was performed throughout the 1980s and 1990s. Its wireless transferred power capacity was 60 kW, and the operational frequencies of the inductive power transfer were 400 and 8500 Hz, achieving a maximal measured efficiency level of 60% with an air gap of 2–3 in. ([Kim et al., 2013](#); [Shladover, 2007](#); [Lechner et al., 1993](#); [Empey, 1994](#); [Ahn, 2013](#)). Although the project demonstrated the possibility of WPT applications for transportation, it did not lead to a commercialization, owing to its low power transfer efficiency and the economic infeasibility of the requisite infrastructural overhauls at the time.

2.3.2. KAIST-OLEV

The first commercialized dynamic wireless charging bus is the On-Line Electric Vehicle (OLEV), developed by KAIST ([Ahn, 2013](#); [Suh and Cho, 2017b](#); [Kim et al., 2013](#); [Foote and Onar, 2017](#)). The OLEV adopts a technology called Shaped Magnetic Field in Resonance (SMFIR), which effectively magnifies the electric waves, and has achieved charging efficiencies of up to 80%. The design concept of the OLEV was first presented in a plenary presentation at the 2010 CIRP Design Conference ([Suh et al., 2011](#)). Since the first demonstration in 2009, the OLEV system has thus far been deployed at four sites in South Korea. The OLEV trolley originally installed in Seoul Grand Park as a pilot project in late 2009-early 2010 has been running as a commercial service since 2011. It travels on a 2.2 km circular route around the park, powered by an underground power supply totaling 372.5 m in four segments. In 2012, two OLEV buses serviced the international exhibition Expo 2012 in Yeosu. Two OLEV buses have also been serving as shuttle buses on the KAIST campus in Daejeon since 2012. The route configurations, velocity profiles, and other operating conditions are well described in [Jang et al. \(2016, 2015\)](#). In August 2013, OLEV was installed in Gumi City, one of the largest industrial cities in South Korea. The 35 km route is serviced by six buses and powered by six charging pads under the road ([Jeong et al., 2015](#)). Gumi added two more OLEV buses to its system in May 2016. The latest site to install an OLEV system is Sejong, a recently developed city that houses many central government offices ([Suh and Cho, 2017c](#); [Ko and Jang, 2013](#); [Jang et al., 2015](#)). Developmental histories of OLEV can be found in [Choi et al. \(2015\)](#), [Rim and Mi \(n.d.\)](#), and [Suh and Cho \(2017d\)](#). The developmental history of SMFIR technology, along with its technical details, can be found in the recent book by [Suh and Cho \(2017b\)](#). Moreover, note that there are numerous patents on the technologies related to SMFIR and OLEV systems. They provide detailed technical information.

2.3.3. PRIMOVE

PRIMOVE is the e-mobility unit of Bombardier Transportation, which is one of the largest suppliers in the rail industry. Its wireless charging solution is targeted to light rail, bus, and automotive fleet operations. Its solution concentrates on static charging, but it also has dynamic charging capability (Highway England, 2015). Through a partnership with German firms Viseon Bus and Gesellschaft mit beschränkter Haftung (GmbH), PRIMOVE has developed a mechanical lifting and lowering mechanism to extend the onboard pickup coils to achieve the most efficient recharging (Brecher and Arthur, 2014). The PRIMOVE system for buses has been tested and deployed in many cities in Europe, including Mannheim and Berlin, Germany, and in Bruges, Belgium (Cirimele et al., 2016; Brecher and Arthur, 2014).

2.3.4. Utah State University and SELECT

Utah State University is actively performing research on dynamic wireless charging solutions. The university is also the home of SELECT (Sustainable Electrified Transportation Center), a research consortium of five partner universities and five affiliate institutions in the United States. SELECT, which was formed at the university in 2016, aims to validate and commercialize wireless charging and the supporting technologies through vehicle and roadway-scale demonstration and pilot projects. The demonstration track at Utah State University consists of a 400 m test track with 75 m precast trenches and power panels for embedding coils. The trenches are easily reconfigurable with different transmitters. The power level of each transmitter is up to 30 kW. The EV bus is equipped with a 60 kWh battery (Tavakoli et al., 2016; Möller, 2017).

2.3.5. FABRIC

FABRIC (feasibility analysis and development of on-road charging solutions for future electric vehicles) is a European consortium of 24 partners including automakers Renault, Peugeot, Citroen, Fiat, Volvo, and Scania, coordinated by the Institute of Communication and Computer Systems (ICCS) in Greece. FABRIC aims to develop, test, and evaluate the efficiency of dynamic wireless charging prototypes to assess the feasibility of a wide deployment of dynamic wireless charging solutions (Amditis et al., 2017). During its four-year project period, starting from 2014, dynamic charging solutions on the prototype EVs under development have been tested in three test sites in France, Sweden, and Italy. The tested solutions include systems developed by Qualcomm-Halo, Polito, and Saet. The French test site primarily tests the Qualcomm-Halo solution on a 100-m-long charging lane. The Italian site, which consists of a 700-m-long track with a 200-m-long wireless charging infrastructure, tests the Polito and Saet systems. This demonstration track is also equipped with a simulation toll collection system and smart grid interfaces. The Swedish test site is primarily for a conductive solution for trucks (de Blas, 2017). The FABRIC project is on the verge of completion, and significant reports from the project are expected to be released in 2018.

2.3.6. Oak Ridge National Laboratory

Oak Ridge National Laboratory (ORNL) is an active institution in the US, performing research on wireless charging EV technology with support from the US Department of Energys Vehicle Technologies Office (VTO) (Brecher and Arthur, 2014). ORNL has partnered with Hyundai America Technical Center and Toyota Research Institute of North America to develop stationary wireless charging solutions for various passenger vehicle models (Onar et al., 2016; Chehab, 2016). ORNL is also doing research and developing quasi-dynamic and dynamic wireless charging solutions (Brecher and Arthur, 2014; Miller et al., 2015). Onar et al. (2016) describes the concept and prototype of a WPT solution developed by ORNL and the mass transit vision of ORNL.

2.3.7. UNPLUGGED

UNPLUGGED was a European project-based consortium with a budget of 2.3-million euros, aiming to investigate how integrating wireless charging EVs with urban road systems could improve the convenience and sustainability of car-based mobility. The main objective of the UNPLUGGED project was to conduct a feasibility analysis of dynamic en-route charging technologies for long-term EV range extension (Unplugged Fianl Report, 2015). UNPLUGGED examined the technical feasibility, practical issues, interoperability, user perception, and socio-economic impacts of wireless charging EVs from September 2012 to March 2015. The consortium was supported by the European Unions Seventh Framework Programme and was led by FKA (Forschungsgesellschaft Kraftfahrwesen. Aachen) and ENIDE Solutions S.L. It included 17 partners from the automotive and power supply industries, R&D centers, and transport operators. During the project period, two wireless charging systems were built in Zaragoza and Aachen. These innovative systems went beyond the current state-of-the-art in terms of high power transfer as they included a 50-kW charging station designed and manufactured by CIRCE. The system allowed for smart communication between the vehicle and the grid and was in line with the latest inductive charging standards, which considered interoperability. The results and outcomes of the project are documented in (Unplugged Fianl Report, 2015).

2.3.8. VICTORIA

VICTORIA (vehicle initiative consortium transportation operation and road inductive application), is one of the projects associated with FABRIC. The primary goal of the project was to investigate the feasibilities of WPT-based electric vehicle and road systems including stationary, quasi-dynamic, and dynamic wireless charging EVs (Bludszuweit, 2016). The demonstration system adopted a U-shaped track-type charging infrastructure similar to the one developed at KAIST OLEV. A maximum power transfer of 50 kW has been developed and operated on a 10-km bus route in Malaga, Spain, since December 2014. In the demonstration system, 10 segmented wireless charging infrastructure systems with a total length of 300 m were installed. In the EV bus, a self-guided control system automatically controls the position of the receiving panel, following the center of the road (Rim and Mi, 2017).

2.3.9. Stationary wireless charging solution

Note that as mentioned earlier, the focus of the present paper is quasi-dynamic and dynamic wireless charging. While the architecture of a few dynamic wireless charging EV systems, such as, the KAIST OLEV, is solely targeted at dynamic wireless charging, most of the quasi- and dynamic wireless charging EV systems have been modified from static wireless charging systems or built upon the stationary technologies. As a result, it is not straightforward to clearly distinguish the type of wireless charging for some prototypes and demonstration models. This subsection introduces some of the solutions originally developed from the stationary type but widely mentioned in the wireless charging technology literature.

IPT Technology, a spin-off of the company Conductix-Wampfler, has developed WPT solutions since 1997. The company has developed and deployed several generations of quasi-dynamic wireless charging buses, in which the buses charge when they are temporarily stopped at bus stops or parked for extended periods. The first version was an electric shuttle in the Rotorua Thermal Park in New Zealand, which started service in 1998. IPT Technology has since deployed their wireless charging solutions to public buses in Genoa and Turin, Italy in 2002 and 2003, respectively. In Turin, a fleet of 23 electric buses are in daily operation, using IPT Technology systems since 2003. The reported annual cost of electricity per bus was about \$9K, a substantial gain when compared against the \$50K cost for to fuel a diesel-powered bus (Brecher and Arthur, 2014). IPT Technology has also deployed wireless charging public buses in Utrecht, Netherlands and cities in the UK, including Milton Keynes, London, and Bristol, since 2014 (IPT Technology Official Website, 2017).

A company spun off from a project at Utah State University, Wireless Advanced Vehicle Electrification (WAVE), has developed both stationary and quasi-dynamic wireless charging transit buses (Fisher et al., 2014). The first prototype, called Aggie Bus, was implemented as a campus shuttle, equipped with a receiver with the same dimensions as the transmitter embedded in the pavement of the bus stops (Cirimele et al., 2016; Bansal, 2015; Brecher and Arthur, 2014). This system allows the transfer of 25 kW at 20 kHz at each bus stop. The power transfer takes place over an air-gap of 15–25 cm, achieving 90% efficiency (Cirimele et al., 2016; WAVE Official Website, 2017). This is the first use of WPT in transportation by a North American entity (Bansal, 2015). WAVEs technology is also being adopted to charge electric buses in Long Beach, California, and to power the Monterey-Salinas Transit trolleys, also in California (Brecher and Arthur, 2014).

There are numerous projects currently underway for static charging personal vehicles, including Qualcomm-HaloIPT, Toyota Motors' joint development with WiTricity, and Plugless Power Solutions, which is being tested by Nissan and Chevrolet. Because the static charging solution and applications are outside the scope of this survey, readers interested in these technologies should refer to the surveys in Cirimele et al. (2016) and Brecher and Arthur (2014).

2.3.10. Remarks on demonstration and commercialization activities

More on-going projects or list of past projects are found in the following literature: Brecher and Arthur (2014), Li (2016), Fisher et al. (2014), Foote and Onar (2017), Cirimele et al. (2016), Bi et al. (2016), de Blas (2017), Highway England (2015), Möller (2017), and Miller et al. (2015).

The goal of this subsection is not to provide a complete list of demonstration projects, prototypes, initiatives, and consortia for wireless charging EV systems. Instead, it discusses the activities widely mentioned in the literature on the systems and operation of wireless charging EVs. Moreover, note that while the activities listed above are specifically for wireless charging EV systems, some of the activities deal with wireless charging as one of the many different subjects. For instance, eco-FEV was a European consortium investigating the economics of electric vehicles, system architecture, energy management, ITS, and other EV-related topics during the period from September 2012 until May 2015. The wireless charging EV system was one among many different topics. The wireless charging-related research literature tied to this project includes (Deflorio and Castello, 2017, 2015; Deflorio et al., 2015a,b). Furthermore, Highways England's electrified road research with the Transport Research Laboratory has often been discussed in the literature, such as Chen et al. (2016), Liu and Song (2017), and Suh and Cho (2017d). The British government announced in 2015 that it would invest 500 million in research on and products related to dynamic wireless charging EV systems (Off road trials for electric highways technology, 2015). However, at the time of writing, this project has not yet been realized and is therefore not discussed in detail in this survey (Green Target, 2016). Table 1 summarizes recent activities related to wireless charging EV systems worldwide, which are widely mentioned in the academic literature.

3. State-of-Art in research

The status of the current research is reviewed from the following five different perspectives.

- **Charging infrastructure allocation:** methods for allocating wireless charging infrastructure.
- **Driving range extension analyses:** analysis methods and evaluation of driving range extension with the wireless charging technology.
- **Cost and benefit analyses:** investigations of the cost and benefit of the wireless charging EV compared with other type of transportation systems.
- **Supporting systems:** models and analyses for supporting systems in operations of wireless charging EVs, such as construction and installation methods, power supply to the charging facilities, electric billing infrastructure, and billing approaches.
- **Miscellaneous:** other perspectives that are not covered in the above including regulations/standardization, traffic simulation, and system architecture issues.

Table 1
Activity summary.

Activity	KAIST OLEV	PRIMOVE	SELECT	FABRIC	ORNL	UNPLUGGED	VICTORIA
Activity category	Commercialized product	Commercialized product	Consortium	Consortium	Laboratory prototype	Consortium	Consortium
Primary organization or coordinator	KAIST	Bombardier Transportation	Utah State University	Institute of Communication and Computer Systems (ICCS), Greece	Oak Ridge National Laboratory	Forschungsgesellschaft Kraftfahrwesen mbH Aachen, Germany	Utility Endesa and CIRCE Research Center
Major funding sources or partners	<ul style="list-style-type: none"> – Initiated with various funding sources from the Korean government – Technology license and sales rights transferred to Dongwon OLEV (Korea) and OLEV-Tech (USA) – Dongwon Industry, Inc. Korea 	Bombardier Transportation	<ul style="list-style-type: none"> – Consortium with 10+ universities in the US and multiple industry partners 	<ul style="list-style-type: none"> – European Union in the Seventh Framework Programme – EUCAR (European Council for Automotive R&D) and ERTICO-ITS Europe 	<ul style="list-style-type: none"> – U.S. Department of Energy's Vehicle Technologies Office (VTO) – Hyundai America Technical Center and Toyota Research Institute of North America 	<ul style="list-style-type: none"> European Unions Seventh Framework Programme 	<ul style="list-style-type: none"> Utility Endesa, Malaga city council, CIRCE and multiple industry partners
Products/demos	<ul style="list-style-type: none"> – Seoul Grand Park trolley (Seoul, Korea) – KAIST campus shuttle buses (Daejeon, Korea) – Gumi transit buses (Gumi, Korea) – Several demonstration projects and demos in Korea 	<ul style="list-style-type: none"> – Transit buses (Berlin, Germany) – Transit buses (Braunschweig, Germany) – Transit buses (Lommel, Belgium) – Transit buses (Mannheim, Germany) – Transit buses (Sdertlje, Sweden) 	<ul style="list-style-type: none"> – Test facility at the Utah State University (Electric Vehicle and Roadway (EVR) Research Facility and Test Track) 	<ul style="list-style-type: none"> – Test and demo, Vedecom/Qualcomm (Versailles, France) – Test and demo with SAET and POLITO solutions (Susa, Italy) 	<ul style="list-style-type: none"> – ORNL Advanced Power Electronics and Electric Machinery facility (Tennessee, USA) 	<ul style="list-style-type: none"> – Test for research in Aachen – Test and demo in Zaragoza 	<ul style="list-style-type: none"> – Testing in Mlaga, Spain
Related website	http://olev.kaist.ac.kr/	http://primove.bombardier.com/	http://select.usu.edu/	https://www.fabric-project.eu/	https://www.ornl.gov/	http://unplugged-project.eu/	N/A
References	Suh et al. (2011), Suh and Cho (2017d) Shin et al. (2014), and Ko and Jang (2013)	Highway England (2015), Möller (2017), and Brecher and Arthur (2014)	Tavakoli et al. (2016), Limb et al. (2016), and Möller (2017)	de Blas (2017), Möller (2017), and Highway England (2015)	Miller et al. (2015) and Onar et al. (2013, 2016)	Unplugged Fianl Report (2015) and FKA (2015)	Bludszuweit (2016), Ahmad et al. (2018), and Rim and Mi (2017)

(continued on next page)

Table 1 (continued)

Activity	KAIST OLEV	PRIMOVE	SELECT	FABRIC	ORNL	UNPLUGGED	VICTORIA
Spec.			Test road consists of a 40 m test track with 75 m precast trenches and power panels for embedding coils. The trenches are reconfigurable with different transmitters. The power level of each transmitter is up to 30 kW				
	<p>Seoul Grand Park trolley</p> <ul style="list-style-type: none"> - Total distance of the route: 2.2 km - Number of charging facilities (total length): 4 (372.5 m) - Type of operation: transit service <ul style="list-style-type: none"> - Number of vehicles: 3 - Battery capacity: 100 kWh - Charging power: 100 kW 	<p>Transit buses (Berlin)</p> <ul style="list-style-type: none"> - Total distance of the route: 6.1 km - Number of charging facilities: 3 - Type of operation: transit service <ul style="list-style-type: none"> - Number of vehicles: 4 - Battery capacity: 90 kWh - Charging power: 200 kW 		<p>Vedecom/Qualcomm</p> <ul style="list-style-type: none"> - Charging power: 20 kW - 100 m charging lane <ul style="list-style-type: none"> - Type of operation: test operation - Partners: Renault, Peugeot, Citron, etc. <p>Polito solutions</p> <ul style="list-style-type: none"> - Charging power: 20 kW - 700 m long track - 2 paved lanes (200 m) <ul style="list-style-type: none"> - Type of operation: test operation 	<p>Dynamic wireless charging experiment (laboratory level)</p> <ul style="list-style-type: none"> - Global electric motors EV - six coil track with - Charging power: 2.2 kW 	<p>Test in Zaragoza</p> <ul style="list-style-type: none"> - Charging station for passenger vehicles (3.7 kW) - Charging station for commercial light duty vehicle (50 kW) 	<p>Test in Malaga</p> <ul style="list-style-type: none"> - 2 static/stationary inductive charging facilities (50 kW) - Dynamic charging lane with 100 m-long (50 kW) <ul style="list-style-type: none"> - Test vehicle: Gulliver U520 ESP/LR (length: 5.3 m) - 20 kWh battery pack
	<p>KAIST campus shuttle bus</p> <ul style="list-style-type: none"> - Total distance of the route: 3.76 km - Number of charging facilities (total length): 3 (60 m) - Type of operation: transit service <ul style="list-style-type: none"> - Number of vehicles: 2 - Battery capacity: 100 kWh - Charging power: 60 kW 	<p>Transit buses (Braunschweig)</p> <ul style="list-style-type: none"> - Total distance of the route: 12 km - Number of charging facilities: 5 - Type of operation: transit service <ul style="list-style-type: none"> - Number of vehicles: 5 - Battery capacity: 60 kWh - Charging power: 200 kW 					
	<p>Gumi transit bus</p> <ul style="list-style-type: none"> - Total distance of the route: 32 km - Number of charging facilities (total length): 5 (144 m) - Type of operation: transit service <ul style="list-style-type: none"> - Number of vehicles: 4 - Battery capacity: 100 kWh - Charging power: 100 kW 	<p>Transit buses (Lommel)</p> <ul style="list-style-type: none"> - Total distance of the route: 1.2 km - Number of charging facility: 2 - Type of operation: test operation <ul style="list-style-type: none"> - Number of vehicles: 1 - Battery capacity: – - Charging power: 40–80 kW 					
	<p>Yeosu Expo shuttle bus</p> <ul style="list-style-type: none"> - Total distance of the route: 600 m - Number of charging facilities (total length): 4 (36 m) - The type of operation: test operation <ul style="list-style-type: none"> - The number of vehicles: 1 - Battery capacity: 100 kWh - Charging power: 100 kW 	<p>Transit buses (Mannheim)</p> <ul style="list-style-type: none"> - Total distance of the route: 9 km - Number of charging facilities: 7 - Type of operation: transit service <ul style="list-style-type: none"> - Number of vehicles: 2 - Battery capacity: 60 kWh - Charging power: 200 kW 					
		<p>Transit buses (Sdertje)</p> <ul style="list-style-type: none"> - Total distance of the route: 10 km - Number of charging facilities: 1 - Type of operation: transit service <ul style="list-style-type: none"> - Number of vehicles: 1 - Battery capacity: 56 kWh - Charging power: 200 kW 					

Each of these research perspectives is based on the topics and approaches driving current research on operations and systems issues for wireless charging EVs. It should be noted that the Miscellaneous category includes research areas and perspectives that are promising but not developed enough to warrant their own category. Please note as well that the perspectives listed here are not mutually exclusive. As a result, a single research article may be covered across more than one perspective.

3.1. Charging infrastructure allocation

The charging infrastructure allocation problem is one of the most actively investigated topics in systems and operations studies of conventional EVs. This is also true for the case of wireless charging EVs. The challenge presented by the allocation problem is to provide logistical insights to support decisions geared toward an optimal distribution of charging infrastructure.

The allocation problem is categorized into two different types based on the scope of the modeling – the *microscopic allocation model* and the *macroscopic allocation model*. The microscopic allocation model, or simply micro-allocation, seeks to find an optimal location for charging infrastructure on a given route or path of a vehicle. The model considers cases in which the wireless charging EVs are traveling only on a given route or path. An example of the model is a public transit bus. Because the vehicle travels on a predetermined route, traffic conditions, velocity profile, and energy consumption are fairly predictable. More detailed modeling can then be constructed based on this micro-allocation. Specifically, micro-allocation approaches are useful when engineers or route planners need to decide the specific locations for wireless charging lanes or for charging points during the planning stage of wireless charging transit bus. The goal of the model is to provide a practical engineering tool to support system-level decisions for the wireless charging-based transit system.

In contrast, the macroscopic allocation model, simply macro-allocation, considers a more high-level view. The primary goal of this type of modeling is to provide scientific insights for the wireless charging EV itself; to evaluate overall traffic behavior affected by the introduction of wireless charging EVs into broader transit systems. Typically, macro-allocation modeling considers the routing of passenger vehicles or commercial trucks that have more freedom in selecting their routes. Because the scope of the model is broader, high-level approximation is unavoidable. Most macro-allocation models adopt a network-based modeling approach, in which the traffic flow is modeled with nodes and arcs. This approach is derived from the well-known location problem, which seeks an optimal location for a facility with a given constraint (Church and Velle, 1974). Typically, in this modeling approach, travel flow from origin to destination is assumed to be known in advance.

Regardless of whether the allocation problem is modeled as macroscopic or microscopic, mathematical optimization is typically used. This optimization technique is used either to directly determine the locations of the charging infrastructure or to support intermediate steps in the process of determining an optimal allocation. Evaluation of the user equilibrium assignment with an optimization technique is an example of the latter case (Fisk, 1980). Work by Liu and Wang (2017), Manshadi et al. (2017), Chen et al. (2017), and Chen et al. (2016) incorporates the user-equilibrium with allocation of the charging infrastructure. There are three types of decision-modeling approaches adopted in these analyses; these are shown in Fig. 2. The first one is the continuous variable approach, in which the allocation of the charging infrastructure is modeled as a set of continuous variables x_i^o and x_i^f that represent, respectively, the starting and ending point of a power track or charging facility i within a continuous search space. The second approach uses the segmented discrete variable, in which the road is divided into multiple segments. A binary variable, typically a set of $\{0,1\}$, is used, depending on whether a power track or charging lane covers a segmentized area. The third approach uses a link-variable approach, in which the variable representing a specific link is a decision variable.

3.1.1. Micro allocation model

Jang and his colleagues were the first to formalize the micro-allocation problem (Chen et al., 2017), and most subsequent work follows the modeling assumptions and considerations provided in this and earlier work, including Ko and Jang (2013) and Jang et al. (2015). The modeling assumptions and considerations are as follows (Table 2):

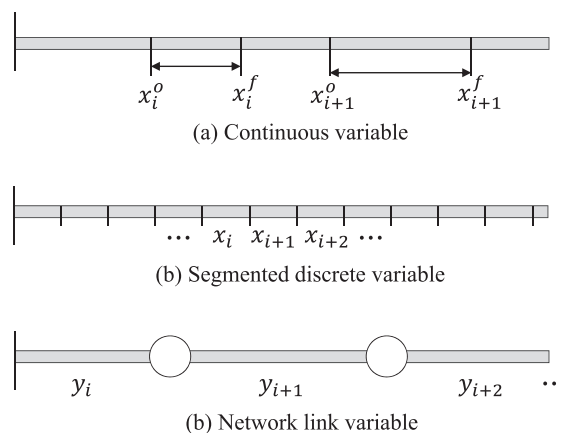

Fig. 2. Decision variable types in the mathematical modeling.

Table 2
Research on charging infrastructure allocation.

Literature	Micro/ Macro	Target vehicle (Passenger/Bus-transit)	Optimization model approach/ algorithm (software or solution approach)	Wireless charging type	Numerical case/scenario
Fuller (2016)	Macro	General vehicles	Link based MIP (CPLEX)	Stationary/dynamic	California freeway
Ko and Jang (2013)	Micro	Bus-transit (single route)	Continuous MIP Meta-heuristic (PSO)	Dynamic	OLEV at KAIST Campus
Jang et al. (2015)	Micro	Bus-transit (single route)	Segmentized MIP (CPLEX)	Dynamic/quasi-dynamic	OLEV at KAIST Campus
Ko et al. (2015)	Micro	Bus-transit (single route)	Segmentized MIP Meta-heuristic (GA)	Dynamic	OLEV at Seoul Grand Park
Jeong et al. (2015)	Micro	Bus-transit (single route)	Continuous Meta-heuristic (PSO)	Dynamic	OLEV at Gumi City
Jang et al. (2016)	Micro	Bus-transit (single route)	Segmentized MIP Meta-heuristic (GA)	Dynamic/quasi-dynamic	OLEV at KAIST Campus and Gumi City
Jang et al. (2016)	Micro	Bus-transit (single route)	Segmentized MIP (CPLEX)	Dynamic/quasi-dynamic/stationary	OLEV at KAIST Campus and Gumi City
Hwang et al. (2017)	Micro	Bus-transit (multi route)	Continuous Meta-heuristic (PSO)	Dynamic	OLEV at Gumi City
Liu and Song (2017)	Micro	Bus-transit (multi route)	Segmentized MIP Robust Optimization (CPLEX)	Dynamic	Campus bus routes at Utah State University in Logan and bus routes at downtown Salt Lake City, Utah
Mouhrim et al. (2016)	Micro	Bus-transit (multi route)	Segmentized MIP Meta-heuristic (PSO)	Dynamic	Hypothetical transportation network
Lee and Jang (2017)	Micro	Bus-transit (multi route)	Segmentized MIP Meta-heuristic (GA)	Dynamic	OLEV at Gumi City
Pantic et al. (2009)	Macro	General vehicles (compact car: Honda Insight; car: Chevrolet Impala; and heavy SUV: Ford Explorer)	MIP (CPLEX)	Dynamic	Demanding urban driving cycle (UDDS), highway driving cycle (HWFET), and highway driving in a mountainous region (HW-MTN)
Riemann et al. (2015)	Macro	General vehicles	MIP converted to MIP/CPLEX	Dynamic	Hypothetical network in Nguyen and Dupuis (1984)
Chen et al. (2016)	Macro	General vehicles	Nonlinear Programming/Heuristic algorithm	Dynamic	Hypothetical network in Nguyen and Dupuis (1984) and Sioux Falls network (topology only) in He et al. (2014) with Nissan Leaf 2013 for vehicle parameters
Chen et al. (2017)	Macro	General vehicles	Nonlinear Programming/Heuristic algorithm	Dynamic	Traffic corridor model in Nie and Ghamami (2013)

1. Each bus line in the system operates on a fixed route.
2. Each bus line has a base station, where all buses start and end their service loops.
3. Once a wireless charging bus completes a service loop, it will be fully charged at the base station before it starts another service loop.
4. The speed profile and the number of boarding/disembarking passengers at bus station are predetermined.

In an early application of the micro-allocation problem, [Ko and Jang \(2013\)](#) proposed an optimization-based approach, first, for the distribution of charging infrastructure, and second, for determining the right battery size for a public transportation system operating on a single route in a closed environment, where vehicles typically operate under regulated velocity and less traffic. The OLEV EV bus currently operating at KAIST is a good example of this type of closed-environment system. The model considers the route as a continuous spatial decision space. The optimization-based approach seeks the starting and end points of each wireless charging lane segment on a specified route in a continuous search space as shown in [Fig. 2\(a\)](#). The total number of segments is also a decision variable. In addition, the model considers the battery capacity as a part of its decision variables. The authors explain that these variables entail a trade-off, between battery capacity and number and length of charging lanes. If the EV bus is equipped with a large battery, fewer and shorter charging lanes need to be installed along the route and vice versa, indicating a clear trade-off between the cost of the battery and that of the charging lanes. The optimization-based approach thus seeks to determine a charging lane allocation in conjunction with an optimally sized battery. In terms of practical applications, this approach is most useful at the initial stage of planning for wireless charging EV-based transportation systems within closed-environments like that at KAIST.

[Jang et al. \(2015\)](#) adopts assumptions and modeling conditions identical to those deployed in [Ko and Jang \(2013\)](#). The difference is that [Jang et al. \(2015\)](#) discretizes the route into multiple small segments, turning the optimization approach proposed by [Ko and Jang \(2013\)](#) into a discrete problem. The model is validated by comparing the results from [Ko and Jang \(2013\)](#). A similar modeling and optimization approach can be found in [Ko et al. \(2015\)](#), in which a nonlinear cost function and genetic algorithm are proposed to solve for the optimization.

[Jeong et al. \(2015\)](#) is the first research to incorporate battery life as part of an economic analysis of wireless charging EV. The cost structure and modeling, which also considers a single-route transit bus case, are similar to those used in [Jang et al. \(2015\)](#), [Ko and Jang \(2013\)](#) and [Jang et al. \(2015\)](#). The idea to include battery life comes from the property of the lithium-based battery, the most widely used battery type for EVs. The performance of the battery (charging capacity and power amount) becomes worse if the depth of charging/discharging is greater and if charging is done infrequently, as compared to frequent and shallow charging/discharging. These conditions suggest that it might be more cost-efficient to install many short power tracks frequently rather than long tracks infrequently. In other words, the battery replacement cost also becomes a function of the power track allocations. Comparisons between modeling with and without consideration of battery life in the cost structure indicated the importance of battery life in long term economic analyses.

The abovementioned studies only consider a single-route bus transit case. However, real-world transit systems are much more likely to contain multiple routes and bus stations, with some segments shared by more than one route, than they are to consist of a single-route. Particularly for downtown areas where major transit routes intersect, significant overlapping is to be expected. This adds a new set of considerations, as it becomes beneficial and efficient to allocate power tracks to segments where multiple routes overlap. Recent studies by [Hwang et al. \(2017\)](#) and [Liu and Song \(2017\)](#) incorporate this property.

In particular, [Hwang et al. \(2017\)](#) offers an extension of [Ko and Jang \(2013\)](#), but relaxes the single-route assumption and provides a general modeling framework for multiple route considerations. Optimization is based primarily on the continuous variable framework in [Fig. 2\(a\)](#), but the model and solution algorithms are numerically validated with those from the segmented discrete model. The OLEV Gumi case is used for empirical study such that the economic benefit of installation on shared routes can be analyzed.

[Liu and Song \(2017\)](#) also considers the multiple route case. Compared to [Hwang et al. \(2017\)](#), the optimization is based on the segmented discrete model. The study is significant in that it is the first to consider the issue of uncertainty in vehicles energy supply and consumption. Note that all of the work previously mentioned here assumes deterministic energy rates, where the amounts of energy supply and consumption are known in advance as deterministic parameters; these assumptions ignore the practical likelihood of uncertainty and may create a risk of not having energy supply to the battery. [Liu and Song \(2017\)](#) uses the set-based robust optimization technique to deal with uncertainty. This deals indirectly with the probabilistic parameters by introducing limits for each uncertain parameter. If the probability distribution of the uncertain parameter is not known then, it would be safe to assume that the parameter is within the worst bounds described in the set. Thus, the problem is formulated as a deterministic optimization but still considers uncertainty. This approach is more mathematically tractable than stochastic optimization approaches, which consider uncertain parameters as stochastic variables ([Bertsimas et al., 2011](#)). [Liu and Song \(2017\)](#) compares the solutions from the deterministic model, which do not consider uncertainty, to those from the robust optimization. As expected, the robust model requires higher cost in the initial investment to hedge uncertainty. But it is interesting to observe from the empirical study that robust optimization requires larger batteries to achieve robustness at the system-level, instead of requiring more power track installations. Applications of these robust optimization techniques as applied to electric vehicles can be also found in [Sarker et al. \(2015\)](#) and [Mak et al. \(2013\)](#).

3.1.2. Macro allocation model

The macroscopic model seeks to address the high-level charging infrastructure by considering traffic flow, driver's route choice, and other traffic-related issues. This modeling perspective is not limited to an individual vehicle traveling on a specified route.

Instead, it considers the social benefit of the charging infrastructure to maximize the number of vehicles that use the infrastructure. The underlying assumptions of this approach are that the location of the charging infrastructure will affect routing choice and thus traffic flow.

Riemann et al. (2015) investigates the optimal location of wireless charging facilities using a flow-capturing location model (FCLM), which seeks to maximize demand coverage by locating a set of facilities (Hodgson, 1990; Church and Velle, 1974).

Riemann et al. (2015) seeks to address the optimal location problem of wireless charging facilities with a finite number of facilities available for deployment. This extended the arc-cover path-cover (AC-PC FRLM) model to explicitly capture the mutual interaction between the location of charging facilities and the resultant network traffic flow. In the optimization modeling, the links are candidate points for dynamic charging infrastructure. Specifically, it assumes that if a wireless charging facility is provided, it will be located in the middle of the links (the centroid node) in the network. The proposed model is also concerned with assigning traffic in the network onto the routes, with considerations for both travel time and the availability of charging facilities. The multinomial logit model stochastic user equilibrium principle is used to capture the routing choice behavior of drivers. It should be noted that the optimization modeling is based on some unrealistic assumptions, such as that the battery is fully charged if an EV is on a link with a power-tracked road, regardless of the battery charging level or that all vehicles traveling in the network model are wireless charging EVs. However, Riemann et al. (2015) is considered as a pioneering work, extending the conventional location model to wireless charging EV.

Fuller (2016) suggests an optimization model to allocate charging facilities, using a liked-oriented set covering location modeling approach. The study evaluates the potential for dynamic wireless charging by considering travel to regional destinations in California. A 200-mile range EV is assumed to be used in coordination with stationary and dynamic wireless charging. An optimization model is constructed to evaluate the optimal allocations of dynamic wireless charging infrastructure at minimum total investment cost, while also meeting the travel requirements between cities (this is based on the location model developed in Wang and Lin, 2009). The proposed optimization problem essentially becomes a flow-based set covering problem. Traffic issues or driver behavior or choice of charging are not considered in the model. The primary focus is on cost analyses rather than charging facility allocation and optimization modeling; as a result, the study empirical findings are discussed below in the section on economic analyses.

Chen et al. (2016) presents an optimization model and algorithm dealing with one of the most critical issues in wireless charging facility allocation. Their approach presented a novel user equilibrium model to describe EV drivers' travel and charging choices when charging lanes are deployed. The model showed that slower speeds will allow more time to charge in the charging lane, but will yield longer travel times. As a consequence, there is a trade-off for EV drivers, pitting energy needs against travel time. With this trade-off, the relationship between traffic volume and actual travel time is no longer described by a single link performance function, as had been done in previous work. As a result, Chen et al. (2016) is considered the first to capture this trade-off behavior. Their proposed model explicitly considers the driver's choice of operating speeds on wireless charging lanes by formulating a new user equilibrium model. Then, with the established user equilibrium conditions, the optimal deployment of charging infrastructure for a given budget is proposed. The algorithms are validated with empirical examples based on both a small-scale network from Nguyen and Dupuis (1984) and a large-scale network from He et al. (2014).

Chen et al. (2017) presents a charging-facility-choice model investigating drivers choice of charging facilities, between plug-in charging stations and charging lanes with dynamic wireless charging, to explore the competitiveness of dynamic wireless charging. Both charging stations and wireless charging lanes are deployed so that EV drivers can choose either option. EV drivers who select charging stations must stop at the stations and thus encounter a charging delay, whereas those who use wireless charging lanes have to equip their vehicles with additional devices to enable wireless charging and may have to pay a higher charging price. However, these drivers will enjoy a less travel time because they will not need to stop for charging. The study first analyzes the charging-facility-choice equilibrium, and then discusses the optimal allocation of charging infrastructure, comparing public and private provisions. The public provision maximizes the social benefit, as if a government agency builds and operates the infrastructure. In contrast, the private provision is such that the infrastructure is built and operated by two competing private companies to maximize their own profits. This study differs from previously mentioned work, because its goal is to provide high-level insights about the competitiveness of dynamic charging against stationary charging; as a consequence of this orientation, it used a highly simplified model, proposed by Nie and Ghamami (2013), in which identical EVs travel on a hypothetical traffic corridor. The model is not intended to specify an allocation of charging stations or power tracks. Instead, it provides a mathematically tractable means to characterize the deployment and operations of charging lanes and stations. The empirical study indicates that dynamic charging is competitive when compared against plug-in charging for drivers with higher value of time (VOT) in the public provision scenario. Although these findings depend on the input data, the finding is still significant in that the study is first to show, with a logical model, that dynamic wireless charging should be deployed initially for commercial fleet vehicles, such as OLEV, for which the VOT is much higher than that of passenger vehicles.

Another consideration is whether the availability of wireless charging infrastructure will alter customers' purchasing behaviors of EVs. More dynamic charging infrastructure can attract customers to purchase more dynamic charging EVs, which would result in an increase in the number of dynamic charging EVs on the road. This dynamic is captured in the study by Liu and Wang (2017), whose optimization model considers the tri-level relationship between government, vehicle choice, and driver. Investment decisions for plug-in charging and dynamic wireless charging facilities are determined at the government level; the purchasing of the EV type – conventional plug-in or dynamic wireless charging – is considered at the level of vehicle choice; and the route choice for a trip is selected at the driver level. Decisions on each level are interrelated. The tri-level optimization model is developed, and a solution algorithm is presented. The primary goal of the study is to assist government planners in the optimal placement of multiple types of EV charging facilities to satisfy the needs of different EV types within a given budget to minimize the social cost.

Ushijima-Mwesigwa et al. (2017) uses a network-based modeling framework and algorithm to find an optimal allocation of wireless charging lanes. The primary goal of the model is to minimize the number of infeasible routes for a given budget. As a result, the model is able to determine a minimum budget to achieve zero infeasible routes – understood as EV drivers arriving at their destinations with a battery charge above a certain threshold. Numerical study is carried out with GIS data of Manhattan.

3.2. Driving range extension analyses

Another category of studies considers the allocation of charging infrastructure as a way to investigate wireless charging systems extension of EV driving ranges. These studies use a standard driving-cycle, determined by a velocity profile of a specific type of vehicle provided by a government or organization that represents driving patterns. Studies in Pantic et al. (2009) and Lukic and Pantic (2013) are an examples of this category, in which a general standardized driving cycle is used to estimate the cost of charging infrastructure under the assumption that the charging infrastructure is optimally allocated.

To the extent that this research deals with the general travel of a vehicle, rather than specific trips, it is similar to macro-allocation model. Pantic et al. (2009) uses a simple optimization technique to allocate charging lanes over a standard driving-cycle. This research supposes multiple scenarios based on a number of variables, including vehicle type (small/large/SUV); driving cycles, defined as low-demand urban driving cycles (UDDS), high-speed highway driving cycles (HWFET), and high-demanding mountain driving cycle (VAIL2NREL); and three different power rates for the power track (20, 40, and 60 kW). Optimization is constructed to minimize the total length of the charging lane and maximize battery life. The model shows that the required coverage for power tracks significantly varies depending on vehicle-driving combination. For example, the 8kWh battery-equipped compact car needs only 0.46% coverage under the urban UDDS driving cycle scenario, whereas the heavy SUV in a mountainous region requires as much as 64.3% coverage. Although the study does not analyze monetary costs, it does discuss the idea of power track allocation in terms of road coverage to achieve a target driving range.

Stamati and Bauer (2013) conducted a simulation study using a standard highway driving cycle (Highway Fuel Economy Driving Schedule - HWFET). The simulation investigates the extension of EVs driving range with varying dynamic charging infrastructure coverage, between 10% and 100% of the highway, at a power rate between 10 and 60 kW. The paper concludes that a 500 km driving range could be achieved for an EV with a 24 kWh battery, 25 kW dynamic charging, and 40% roadway coverage.

Chopra and Bauer (2013) also conducted a simulation-based study to investigate the driving range extension of EVs using wireless charging for urban and highway driving scenarios. The two case studies show that considerable driving range enhancement can be achieved by using wireless charging infrastructure for charge replenishment when an EV is idling at a traffic signal in the urban driving scenario, or when it is in motion in the highway driving scenario. The study shows that for an EV with a 24 kWh battery, 90% efficiency of the power supply from the charging infrastructure, and 20% road coverage, the expected driving range can be extended by an estimated 12% for 10 kWh batteries and 217% for 40 kWh batteries, respectively.

Shekhar et al. (2016) provides a case study to analyze the initial investment cost of a fleet of wireless charging electric buses that must achieve a driving range of 400 km. The study proposes a high-level investment cost estimation model. For the cost estimation of the power track, simulations and regression are used. Standard driving cycles with different parameters are simulated first. Then, based on the simulation results, linear regression is used to estimate the relationship between the percentage of coverage for the charging facilities over the required road and the battery level at the end of the trip. Various cases are investigated with different parameter settings, such as the road coverage of charging facilities, the battery size, stopping times, and charging power level. The case study indicates that a 500 kWh battery is optimal. However, this result – the very large battery capacity – somewhat contradicts those of Bi et al. (2015), which indicated that wireless charging technology is promising due to the potential of downsizing the battery. Bi et al. (2015) claims that their empirical study shows that wireless charging solutions can reduce the size of the battery by one-third the weight of a benchmark plug-in battery. Of course, no direct comparison can be done across these two simulations, because they rely on different assumptions and parameter settings. Further investigation is still needed to propose an appropriate size for the battery for wireless charging EV.

García-Vázquez et al. (2017) compares a dynamic wireless passenger EV equipped with a 24 kWh battery driving on three different traffic road scenarios (motorway, highway and urban stretch), each characterized by a different traffic flow (intensity and speed) and length. The results show that in the urban stretch, the energy transferred to the EV presents an average value of about 0.6 kWh/km, whereas on the highway it is 0.25 kWh/km.

3.3. Cost benefit analysis and environment assessment

Cost and benefit analyses are concerned with estimating investment (or operational cost) and economic benefit of wireless charging-based transportation. There are some studies exclusively focusing on these cost and benefit evaluations, whereas others deal with these issues as part of validating optimization techniques, traffic models, or other economic assessment methods. In this section, both cases are discussed. Cost-benefit analyses can be divided into initial investment cost analyses and operational cost analyses. The initial investment analyses estimate the installation cost of the wireless charging EV, focusing mostly on transit fleets. Operations cost analyses are concerned with evaluating the costs of operating wireless charging EVs over a time. Compared to the previous two categories, environment assessment – lifetime assessment and environmental impact analyses – includes not only the cost of investment or vehicle operation but also the cost of the entire energy logistics – energy generation, conversion, and transmission. Table 3 lists papers based on these categories.

Table 3
Summary of the cost-benefit analysis and environment assessment.

Literature	Category	Case/vehicle type	Note
Fuller (2016)	Initial investment, operations cost	California highway/ passenger EV	Comparing conventional gasoline refueling
Ko and Jang (2013)	Initial investment cost	OLEV at Seoul Grand Park/ transit bus	Using OLEV cost figures
Jeong et al. (2015)	Initial investment cost	OLEV at Gumi/transit bus	Considering Battery life time
Jang et al. (2016)	Initial investment cost	OLEV at KAIST and Gumi/ transit bus	Comparing stationary, quasi-dynamic, and dynamic WC
Bansal (2015)	Operations cost		Comparing plug-in and WC
Bi et al. (2015)	Lifetime assessment and environmental impact	Ann Arbor-Ypsilanti metro/transit bus	Comparing to plug-in EV
Bi et al. (2017)	Lifetime assessment and environmental impact	Ann Arbor-Ypsilanti metro/transit bus	Comparing to plug-in, diesel, and hybrid bus
Park and Jeong (2017)	Initial investment cost/operation cost/energy cost	OLEV general/transit bus	Reporting the operational cost and investment cost of OLEV at Gumi City and comparing to those of CNG based bus

3.4. Cost and benefit analysis

Fuller (2016) conducted a case study to analyze the potential for a wireless charging infrastructure by considering travels to different regional destinations in California. Different scenarios in which static and dynamic wireless charging infrastructures are installed on major freeways in California are considered. Large cities and leisure destinations, along with likely travel routes between respective origin and destination pairs, are modeled as a travel network. The optimization model, based on work by Wang and Lin (2009), evaluates the allocation of infrastructure. Different combinations of wireless charging power (dynamic charging level from 20 to 120 kW) and various vehicle ranges (between 100 and 300 miles) are evaluated. The case study indicates that travel between popular destinations could be achieved with a 200-mile EV and a 40 kW dynamic wireless charging infrastructure at a cost of approximately \$2.5 billion US dollars. This cost can be reduced to less than \$1 billion US dollars if the charging power is increased to 100 kW or greater. Dynamic charging, coupled with static charging, proves to be more cost effective than gasoline over a 10-year period. The case study also shows that even at very low battery prices of \$100 per kWh, dynamic charging can be more cost effective for extending range than increasing battery capacity.

Ko and Jang (2013), Jeong et al. (2015), and Jang et al. (2016) all investigate the initial investment costs to implement a wireless charging transit bus system for a single route. The initial investment includes the cost of the infrastructure for the charging lanes and the total battery cost for the fleet of buses. Battery cost is included as a part of the initial investment because the battery size is directly related to the power track allocation requirements. Each bus needs to equip one pack of batteries; the total battery cost for the route is therefore determined by the cost of a pack of battery multiplied by the number of buses in the fleet. This assumes that all buses that operate on the route use the same battery size. The charging lane cost is broken into variable and fixed costs; the variable cost depends on the length of charging lanes, whereas the fixed cost is incurred regardless of the length of the charging lane. The variable cost captures the fact that longer charging lanes entail higher material and construction costs. The fixed cost includes the cost of connecting a facility in a charging lane to the power grid, the inverter cost, and other material costs that are incurred when installing a charging facility, regardless of the length. With this cost structure, it might be more cost-efficient to construct a smaller number of long charging lanes than a larger number of short lanes.

Ko and Jang (2013) estimates the minimum cost of installing an OLEV-based trolley at Seoul Grand Park using an optimization technique. The cost is about \$640,000, which includes cost of batteries and charging infrastructure, but excludes the bus units, construction, and labor. The cost sensitivity analysis shows that as the cost of battery goes up, the optimization mechanism recommends the installation of more charging infrastructure and vice versa.

The primary focus of Jang et al. (2016) is to analyze the initial investment cost figures between stationary, quasi-dynamic, and dynamic wireless charging transit bus systems. Using the optimization methods and algorithms developed by Ko and Jang (2013) and Jang et al. (2015), this study extensively compares the three different types of dynamic wireless charging transit systems. The OLEV system at KAIST (short trip) and at Gumi City (long travel) are analyzed empirically. The interesting finding here is that dynamic wireless charging is less cost efficient for a short trip service. Dynamic wireless charging can be competitive with the stationary or quasi-dynamic options if the bus operates a minimum travel distance. The study also found that the OLEV-based transit system at Gumi City needs to have at least 18 buses in operation to be economically competitive with the stationary and quasi-dynamic solutions.

Jeong et al. (2015) uses an initial cost estimation technique similar to that in Ko and Jang (2013), but it considers the cost of battery life over the lifespan of the service for OLEV at Gumi City. The proposed cost model includes battery performance over the battery lifespan because it is continuously charging and discharging. This paper points out that frequent-shallow charging with dynamic charging is better than infrequent deep-charging with plug-in or stationary charging when considering battery lifetime. It estimates a cost of approximately \$11 million dollars for stationary charging transit buses, which could be reduced by around 20% to \$9 million if replaced with dynamic charging. This cost reduction derives not only from the shared resource of the wireless charging infrastructure, but also from the lifetime improvement of battery life with dynamic charging.

Park and Jeong (2017) reports on the economic benefits of the OLEV by comparing it with the operational costs for Plugin Hybrid EV (PHEV). The cost analysis shown in the report is significant because it provides one of the few figures based on actual operations costs for a wireless charging transit system. The data is collected from the OLEV system at Gumi City, where the No. 7 transit line is operated by OLEV buses and compressed natural gas (CNG) buses, which are widely used in South Korea's public transit systems as an alternative to the conventional diesel buses. Because these two systems operate on the same routes (approximately 259 km), an operational cost comparison can be done easily; such a comparison revealed that the yearly costs of operating OLEV and CNG buses are \$14,136 and \$52,932, respectively. These costs are calculated based on energy efficiency (km/kWh vs. km/l) and energy cost (\$/kWh vs. \$/l), suggesting that OLEV buses save 73% of energy costs when compared to a CNG bus. The study also projects that, under the same maintenance cost, the 10-year lifetime cost of the OLEV and CNG buses, including the bus costs, are \$591,369 and \$729,320, respectively, without government subsidies, suggesting that OLEV is more competitive than CNG buses in terms of both short-term operations and long-term investment. Of course, this figure does not include the charging infrastructure cost; nonetheless, the cost of an OLEV is expected to decline significantly, the study authors argue, if they were to be mass produced. The report goes on to estimate cost figures for OLEV-based passenger cars, noting that a medium-sized vehicle, equipped with OLEV technology at 5 kWh, would cost approximately \$32,090. It also projects that the construction and installation of wireless charging infrastructure would cost \$726 million, if an installation cost of \$0.5 m/km on the 6% of the total traffic lanes in Seoul can be assumed. These suggestions imply that such an investment could serve 60% of the total travel by passenger cars within Seoul.

Nicolaides and Miles (2015) investigates whether the adoption of wireless charging EV infrastructure at the national scale is technically feasible. With a qualitative analysis based on existing technical documents, surveys, reports, and academic work, the study concludes that the wide-scale adoption of the technology is feasible and can be a major driver towards a more sustainable, environmentally friendly and socially responsible transport sector.

It should be noted that the data used across the various studies considered here are quite variable. For instance, the cost of a wireless charging lane in Fuller (2016) is \$4 million per lane-mile, whereas in Chen et al. (2017) a lane-mile is estimated at 0.8 million which, in turn, is based on the figure used in Jang et al. (2016). As such, it is worth mentioning that the rapid development of wireless charging technologies can significantly affect the empirical data and that the findings and conclusions drawn from the results should therefore not be treated as conclusive.

3.4.1. Environment assessment

Bi et al. (2015) is considered one of the first studies to investigate the lifecycle energy and greenhouse gas emissions of wireless charging EVs. This study uses lifecycle assessment (LCA), the same method used to evaluate the potential environmental impact on the total lifecycle of a product or system. With this method, they compare lifecycle energy and greenhouse gas emissions across plug-in and wireless charging for an all-electric bus system. The bus system modeled for the assessment, consisting of 67 buses operating 21 routes, is based on an actual transit bus system serving the Ann Arbor and Ypsilanti areas in Michigan, called *TheRide*. In the model, all bus fleets operate with either wireless charging-based or plug-in based buses. For the analysis of plug-in buses, each bus is assumed to be equipped with a battery that has enough capacity to serve the length of the route, which is 458 kWh. For the wireless charging buses, it is assumed that a total of 428 stationary and quasi-dynamic wireless chargers are installed at major bus stops, transit centers, and parking lots. The results indicate no significant differences between the plug-in and wireless charging systems in terms of cumulative energy demand and global warming impact. The wireless charging system consumes 0.3% less energy and emits 0.5% less greenhouse gases than plug-in charging over the total lifecycle. However, the study also indicates that energy and greenhouse gas emissions of the wireless system can be further reduced by improving wireless charging efficiencies.

Building upon Bi et al. (2015), Bi et al. (2017) integrated the LCA approach with a lifecycle cost model (LCA-LCC) to model a wireless charging bus system. LCC analysis provides a holistic evaluation of costs, from capital investment to use-phase operation and finally to the end of the lifecycle. Bi et al. (2017) studies the same bus system modeled in Bi et al. (2015). Using the integrated model, the cumulative costs and total costs per bus-kilometer are analyzed across wireless charging, plug-in, and conventional diesel-based bus fleets. The study concludes that a wireless charging system has a lower overall LCC compared to a plug-in charging system. Moreover, wireless charging electric buses are found to be more economically competitive than conventional diesel, diesel hybrid, and plug-in charging electric buses for the scope of an entire lifecycle. However, the article also emphasizes that there is considerable uncertainty for the results, which remain dependent upon favorable battery pricing, charging efficiency, and other related costs. Both Bi et al. (2015) and Bi et al. (2017) do not consider the optimal allocation of the wireless charging points. The bus routing model used in both analyses is assumed to have wireless charging infrastructure at almost every major stopping point. Moreover, they do not consider that utilization will affect the life and maintenance cost of the charging infrastructure.

3.5. Supporting systems

3.5.1. Construction and installation

It is critical to understand the construction issues that wireless charging EV infrastructure entails before installation and maintenance costs can be adequately evaluated. Unfortunately, very little of the literature discusses construction issues, owing in large part to the limited number of implemented wireless charging systems, other than as testbeds. Jung (2017) provides a report on the installation of the charging infrastructure based on first-hand experience of installing an OLEV system, offering descriptions of the installation process, requirements, and construction steps. Pictures of the various stages of the installation and test procedures conducted during the installation process are also presented. Chen et al. (2015) also discusses expected challenges and issues for the road-installed power tracks and road maintenance. This paper also proposes potential methods to improve the structural integrity of

the road with power tracks.

Gill et al. (2014) suggests a business model to fund the wireless charging infrastructure. The model specifies the role of public and private agencies and provides a payment scheme for both EV and non-EV drivers. Although the model remains at the proposal level and has received no rigorous analysis based on either quantitative methods or case studies, it is nonetheless considered the first paper to discuss the infrastructure funding issue.

3.5.2. Power supply, pricing, and billing infrastructure

Pricing the electricity for the wireless charging EV is a central issue in the commercialization of the technology. In particular, if the wireless charging EV is expanded to personal vehicles and charging infrastructure is shared with non-EVs, the pricing issue will be critical in the operation of the system. The literature on pricing suggests that it must include both a billing policy and the requisite infrastructure for billing.

Sarker et al. (2017) considers the challenges of power-load balancing and congestion. The study investigates the power-load and congestion caused by wireless charging EVs using simulation and proposes a game theory model, based on a distributed power schedule framework, to find an optimal schedule between wireless charging EVs and the smart grid. This work assumes that the smart grid is capable of processing data and communicating with others and of course is also connected with the charging sections. While driving, wireless charging EVs receive energy from the smart grid via power tracks.

He et al. (2013) proposes two mathematical models to determine optimal pricing schemes for electricity and the roads. The first is concerned with a first-best condition, in which a government agency controls the operations of both the regional transportation and power transmission networks and aims to maximize social welfare associated with both, defined as minimizing the sum of the total travel time cost and generation cost of electricity. The second scenario considers a more practical second-best case, in which the government agency only manages the transportation network while the power network is operated by an independent system operator (ISO) using locational marginal pricing. The ISO accepts supply and demand bids submitted by market participants, which are buyers and generators, and is responsible for determining the power supplies to meet the demands with the dual objectives of minimizing power generation costs and ensuring system security. In this case, the price that the ISO charges for electricity at each location will be the locational marginal price. Although the traffic authority has no control over the power market, the agency can participate in the wholesale market as a buyer; it will pay ISO, at locational marginal prices, for the dispatched power used to charge electric vehicles. By contrast, the agency can adjust the retail price of electricity at each link to affect drivers route choices. Under this second-best scenario, He et al. (2013) seeks an optimal pricing strategy to maximize social welfare associated with the transportation system.

Manshadi et al. (2017) addresses the issue of the interdependency between traffic routing and the payment schemes for the wireless charging EVs. The study proposes a decentralized optimization framework to consider the effects of wireless charging on electricity and transportation networks. The framework enables one to simultaneously evaluate: (1) the effects of electricity demand imposed by the strategic wireless charging of the EVs on the price of electricity, and (2) the effects of electricity pricing and availability on the EVs traffic flow within the transportation network. The underlying assumption is that the EVs behavior on the network will be captured by a deterministic user equilibrium, in which all paths that connect an origin and destination pair have the same total travel cost. The case studies are conducted under the assumption that the power is generated from a renewable source such as thermal generation or wind units. It should be noted that this study did not consider that fact that greater congestion on a traffic path can provide more charging opportunities for the EVs on the path, resulting in more power usage.

3.5.3. Billing infrastructure

As Hussain et al. (2015a) has addressed, a billing policy is challenging. Unlike road usage-based payments for a conventional toll collection on the highway, billing for wireless charging EVs should consider the amount of electricity used by each vehicle. A vehicle with a fully charged battery should not be charged the same amount for a vehicle with an almost empty battery, even if they are driving on the same charging lane. Seminal work by Hussain et al. (2015a) and Hussain et al. (2015b) propose a secure and privacy-aware fair framework for billing and authentication of wireless charging EVs. The proposed framework is based on the assumption that the power track consists of multiple segments and billing is done on segment-by-segment basis, where each segment delivers a constant amount of energy.

3.6. Miscellaneous

3.6.1. Regulations and standardizations

Kalialakis and Georgiadis (2014) and Kalialakis et al. (2016) provide surveys of the regulatory frameworks pertinent to WPT systems. Readers can find the state-of-art on standardization and regulatory activity around wireless charging EVs, including the International Electrotechnical Commissions (IEC) Technical Committee on Electric vehicle (IEC, TC 69, 2017), the ISO Road Vehicles-Electrically Propelled Road Vehicles dealing with vehicle operation conditions, vehicle safety, and energy storage installation (ISO/AWI PAS 19363, 2017; Pereirinha et al., 2016), the Society of Automotive Engineers (SAE) standardization principles, the work of a taskforce called J2954 on wireless charging for vehicles (SAE J2954 Overview and Path Forward, 2017), and the work of the IEEE Industry Standards Technology Organization Electric Vehicle WPT, with a focus on motion wireless charging (IEEE ISTO, 2017; IEEE Standards, 2017).

Cho (2017) and Jung (2017) report on safety regulation requirements and standards according to which testing and evaluations were performed during the installation and deployment of the OLEV system. These reports also provide how existing standards and

regulations should be adapted for commercialization of the system.

3.6.2. Traffic simulation

Building on Deflorio et al. (2015a) and Deflorio and Castello (2017) proposes a simulation framework for medium-sized freight vehicles operating on wireless charging lanes. A specific traffic model is developed based on a mesoscopic traffic simulation model that incorporates both the traffic behavior and energy state of each EV, based on the assumption that vehicles are operating in a fully cooperative manner, in which advanced driver assistance systems control both the speed of each vehicle and lane selection.

3.6.3. System design and architecture

When a wireless power transmission system is designed, it has to be done in a systems context. Specifically, the power transmission is the subsystem of the system, which is the EV and as a result, the subsystem should be carefully designed to meet the requirements defined at the systems level. That is, the design of the wireless charging system in isolation from the requirements of an electric transportation system may lead to a wrong conclusion. The OLEV was designed using a systematic design method, axiomatic design (Hong and Park, 2010; Suh, 2012; Suh et al., 2011). Suh and Cho (2017a) describes the detailed process of the system design issue and provides the process of defining the system-level functional requirements (FRs) and how the WPT system is designed to meet these system-level FRs using an axiomatic design method. This is one of the few articles to address the system design issue and describe the detailed design process of the WPT system in the context of system design.

The system architecture is a high-level structural configuration that characterizes the system. In particular, the system architecture of EV is defined as the structure of the charging and energy transferring mechanics from the energy grid to the vehicles motor. A primary goal of architectural analysis is to provide a high-level perspective of the energy flow from a structural perspective (Emadi et al., 2005). For example, hybrid EVs are distinguished into two classes from the perspective of system architecture, serial- and parallel-hybrids, which reflect different ways that the internal-combustion (IC) engine receives energy flows.

Jang et al. (2016) first defined the architectural characteristics of wireless charging EVs, identifying how they differ from conventional plug-in EVs. However, the term architecture here is based on the charging type rather than energy flow generated from the engine, meaning that system architecture equates to charging architecture. Jang et al. (2016) also presents use as the ratio of the vehicles drivable time to available time: the EV is drivable only if it has enough energy in the battery. For the conventional plug-in EVs, the vehicle is not drivable when it is being charged. Therefore, the charging frequency, determined by a driving range, together with charging time, directly impact the vehicles use. The study argues that, in recent decades, EV developers and engineers have been working to improve this use by improving the battery density (thus reducing the charging frequency) or by reducing its charging time. The hybrid-EV is also a result of this effort under this architectural paradigm. The study claims that wireless charging EVs are a new type of EV altogether because they decouple charging and driving. The improvement of the use of an EV can be achieved by architectural redesign – dynamically charging while the EV is in motion. The study provides the technological value of the wireless charging EV in terms of its system architecture.

Although Pantic et al. (2009) does not exclusively investigate the system architecture issue, they use a system architecture perspective to compare wireless charging EVs with batteries with those with an ultra-capacitor. Note that ultra-capacitors are widely used for energy buffers. Its energy holding and access capacities differ greatly from those of a battery. This means that its energy flow mechanisms are different and, as a consequence, so too are the considerations for allocating wireless charging facilities. The OLEV at KAIST also investigated a new architecture for wireless charging EVs – combining the battery and ultra-capacitor (OLEV Annual Progress Report, 2010). The researchers at KAIST compare developmental costs and operational costs between battery-only and combined battery and ultra-capacitor wireless charging EVs, although this remains only a high-level feasibility study with no conclusive results.

4. Future research areas

This section proposes promising new research directions. Note that the goal is not to provide a complete list of potential topics, but rather to offer possible directions based on the survey of research presented in the previous sections. These are organized into two topic groups, one that further investigates key operations and systems issues identified by the literature review (incorporating uncertainty, battery life considerations), and the other focused on extending the study domain (into passenger vehicles, ITS, and allocations).

4.1. Incorporating uncertainty

Although there is uncertainty in charging and discharging, very few studies incorporate this uncertainty in the modeling, with the exception of the work down by Liu and Song (2017). As mentioned in the previous section, Liu and Song (2017) uses a robust optimization approach to consider the uncertainty introduced by charging and discharging. This model deals indirectly with the parameters of uncertainty by introducing the concept of uncertainty limits for each variable, a technique that is appropriate if no information about the probability distribution of uncertain or stochastic variables is available but minimum and maximum bounds are known. This means that no study has dealt with uncertainty directly, despite the inevitable uncertainty raised by vehicle speed, road conditions, driving alignments, and other road or driving conditions.

Because no quantitative investigation has been reported, further investigation – whether rigorous simulation or experimental study – is needed to determine what types of models would be appropriate to describe or model such uncertainty. The approach taken

in Birrell et al. (2015) might be a good example in experimental analysis of charging uncertainty. The study focuses on parking misalignment for a stationary charging EV as a source of uncertainty. Although the work does not directly address dynamic wireless charging EVs, its approach and methods are informative. Uncertainty here was approached both from a human factor perspective, focusing on human driving behavior, and from a traffic pattern approach with standard driving cycle data. Regardless of which approach is used in further research, a logical foundation is needed to build statistical charging models as a basis for developing advanced charging infrastructure allocation simulations and for recommending and validating safety factors in the design of wireless charging EV systems.

4.2. Battery lifetime consideration

Although it is widely accepted that wireless charging EVs can use smaller batteries, their use may not guarantee long-term economic efficiency of the system. Studies have shown that batteries that are too small have a negative effect on overall battery life because they are prone to deep-discharging cycles that aggravate battery degradation (XU et al., 2013; Bi et al., 2015; Jeong et al., 2015); and if batteries are short-lived, they will need to be replaced frequently, leading to increased battery costs overall. As such, the use of larger batteries may be more economically sound from a long-term perspective. This quick example suggests the importance of considering battery life when designing wireless charging EV systems.

Empirical evidence suggests that the capacity of a battery will degrade significantly throughout its lifetime. As such, studies no longer consider battery capacity as a static variable, as had been done previously for modeling wireless charging systems, for example, in Jang et al. (2015), Ko and Jang (2013), and Hwang et al. (2017). Rather, battery capacity instead must be treated as a dynamic variable that decreases over the battery's lifespan.

Jeong et al. (2015) first investigated the issue of battery degradation, but few follow-up studies have yet been reported, possibly because incorporation of battery life creates a strong nonlinear property in the model, which makes the analysis mathematically intractable and the development of cost-benefit analyses and optimal allocation models particularly challenging. Furthermore, to consider battery life in the analysis requires expert knowledge on different battery types and capacities. This suggests that more collaborative work is needed between battery experts and operations and systems researchers.

4.3. Passenger vehicles

Most studies of charging infrastructure allocations focus on public transit buses and routes, in which vehicles are traveling on fixed and predefined routes. This is because, as mentioned earlier, most commercialized or prototyped versions of the dynamic wireless charging EVs are found in public transit buses. At the time of writing, automakers are beginning to introduce passenger-type dynamic wireless charging EVs, and governments have begun to fund wireless charging EV infrastructural projects; for example, the British government is funding an electrified road project in which one lane of a highway is being converted to a wireless charging lane with any type of wireless charging EV – whether a public bus or a passenger vehicle – capable of charging when on it. Automakers, policy makers, regulators, and traffic and transportation planners are currently seeking answers to questions such as:

- What is the appropriate battery size for a wireless charging passenger EV?
- How much wireless charging infrastructure should be installed in a city?
- Is installation of a small number of long charging lanes better than installation of a large number of short charging lanes, or vice versa?
- How do installed charging lanes affect traffic?

A pioneering work has investigated some of these issues (Chen et al., 2017). However, plenty of work is still needed to investigate the application of wireless charging systems in passenger EVs.

4.4. Intelligent Transportation Systems (ITS)

In the era of Big Data and attendant advances in intelligent transportation systems (ITS), it is a natural step to incorporate wireless charging EVs with ITS. Real-time traffic conditions and the locations of the wireless charging lanes and stations can be shared with EV drivers. The development of real-time routing algorithms for wireless charging EV drivers is one example of a topic with great potential; evaluation of optimal velocity profiles for drivers for a given route, with real-time traffic conditions, and information about charging lanes and stations, is another. In such systems, the operations of wireless charging EV are coupled with internal information, such as the drivers habits and patterns and the vehicles battery level, and with external information, such as traffic conditions and charging infrastructure locations. Because the role of ITS is to provide drivers with these internal and external data points, and eventually to assist drivers in making good decisions, a number of interesting topics and ideas on wireless charging operations can be proposed in conjunction with ITS.

4.5. Energy and environmental studies

Environmental and energy issues are a great concern these days. Although there are numerous government reports and considerable media coverage discussing the environmental and energy effects of dynamic wireless charging EVs, analyses performed with

a rigorous model and scientific approaches are limited. As mentioned earlier, Bi et al. (2015) and Bi et al. (2017) are the pioneers investigating the energy and environmental issues related to wireless charging EV systems with scientific modeling approaches. Extending their work is definitely a good research area. For instance, the battery replacement issues in the environmental assessment might provide insight into wireless charging EVs. Furthermore, the environmental and energy impacts of the entire wall-to-wheel process is a promising research area.

4.6. Power grid and wireless charging EVs

There are numerous papers analyzing the effect of EVs on the power grid (Green et al., 2011). Most of the studies were performed for conventional EVs with a mobility pattern, and charging was mostly done at home overnight and occasionally at a public or commercial charging station during the day. However, this assumption of the charging pattern is no longer valid if wireless charging becomes the norm for EVs. Therefore, systematic studies are required to investigate the effect of wireless charging EVs on the power grid, such as the power demand pattern across time of day or geographical regions, and the relationship between the installation of the wireless charging infrastructure and the power load in the grid. Moreover, the power distribution design is expected to change when the wireless charging infrastructure becomes widespread. A higher power demand is estimated along roads with wireless charging. The distribution network design must address this issue. Another interesting area is the integration of renewable energy sources such as solar panels and wind turbines with the wireless charging infrastructure. The penetration of more renewable energy sources into the energy market is shifting the power generation and distribution industry. The effectiveness of the integration of the wireless charging infrastructure with wireless charging in the form of distributed energy is a promising area of research. It is known that the research consortium led by the Utah State University, SELECT, installed a test track of wireless charging EVs with solar panels. Installing such a testbed and investigating the effectiveness of the integration or developing an energy distribution logic or algorithm are also promising areas of study.

4.7. Other applications

The application of WPT in transportation is not necessarily limited to transit or passenger vehicles. Yoon (2017) introduces the application of WPT to special purpose transportation systems, such as cargo transportation in airports, container transports at harbors, and cargo transporters in warehouses. Helber et al. (2018) considers the location planning for wireless charging systems for electric airport passenger buses. Ko and Jang (2018) proposes a design method of an operation profile for wireless charging electric tram systems.

To a large extent, material handling systems in factories are also transportation systems for which WPT technologies have been adopted for more than 10 years, particularly in semiconductor and LCD factories (Hwang et al., 2016; Jang et al., 2005). There is plethora of interest in research for these applications. Another area that can be explored is systems design for wireless charging-based autonomous vehicles. With the rapid development of autonomous driving technology, it is also projected that electric charging will be introduced for autonomous vehicles in the near future. At such point, it will be a natural step that autonomous EVs to adopt automated charging mechanisms (it would be somewhat absurd to imagine the driving being done autonomously but charging still being performed manually). Wireless charging will be integral to such vehicles operations.

5. Conclusions

This survey provides the first overview of the state-of-the-art in operations and systems research into wireless charging EVs. The technology is still in early developmental stages, and operations and systems-related research has yet to fully mature, so investigations into current research activities is critical. This survey work has broad applications for the research community, industry, and regulators and policymakers.

The survey first discussed the current state of wireless charging EV systems deployment and commercialization projects, so that readers understand the actual technological development status. It is worth understanding these activities because most operations and systems-related researchers refer to these projects to convince readers of the value of their proposed study. The notations, terms, and definitions are also reviewed in this section, before describing in greater depth the components of the wireless charging EV as used in the existing publications. Note that these terms and definitions have yet to be standardized, and as such clear specification is critical for surveys of technology at this stage. It also identifies how different terms and definitions are used in other studies.

The main part of the survey focused on the state-of-the-art in wireless charging EV, reviews the existing publications from five different perspectives: charging infrastructure allocation; driving range extension; cost and benefit analyses; supporting systems; and miscellaneous perspectives. With the perspective-based review, a single paper can be reviewed from more than one perspectives. The most active research area is charging allocation analyses, which propose methods for optimal allocation of charging infrastructures. Cost-benefit analyses for wireless charging EVs and range extension analyses are also widely studied areas.

The paper then moved to propose future research directions: the incorporation of uncertainty into modeling; research on passenger vehicles; battery life considerations; ITS; and applications. These areas are proposed based on the level of completeness of the existing literature (incorporating uncertainty, battery life considerations) and on extensions of the study domain (passenger vehicle, ITS, and allocations). Note that these proposed directions are not a complete list but are areas that demonstrate promise for extending existing research.

Almost all of the papers discussed in this survey consider dynamic wireless charging technology to be a promising solution for

future EVs. However, there is also a threat to this technology. For instance, [Chen et al. \(2012\)](#) argues that dynamic wireless charging EVs are not competitive when compared to battery-swapping EV buses in terms of technological maturity. In South Korea, some municipal governments are adopting battery-swapping EV buses as an alternative to conventional diesel-based EVs ([Kim et al., 2015](#)). Therefore, some researchers have claimed that the battery-swapping solution might be a threat to wireless charging EVs. At this point, it might be too early to conclude which technology is more competitive. A cost and performance analysis comparing these two technologies might be good research topics for the future. Some scholars have also argued that ultra-fast charging technology and the advancement of battery technology might make dynamic wireless charging redundant ([Wireless Charging Road for Electric Buses Will be Built in Israel, 2017](#)). However, it is also true that fast charging might significantly reduce the cost of wireless charging infrastructure because the charging amount per length of wireless charging lane would be increased more power could be transmitted with a shorter charging lane. The effect of fast charging on the economics of wireless charging EVs is also an interesting topic. In summary, there are numerous threats as well as opportunities related to WPT applied to EVs. Investigating these issues with analytical rigor is a task for the future.

Research into the operations and systems of wireless charging EVs is still evolving. Most methods have not yet been tested on actual systems. The cost figures also may not be correct because wireless charging EVs have not yet been mass produced. Therefore, the numerical results and conclusions drawn in most papers should be treated as preliminary. However, this too should be considered a research opportunity; the validation of methods and results is a primary responsibility for the academic community.

Acknowledgement

This work was supported by the National Research Foundation of Korea funded by the Korean Ministry of Education through the Basic Science Research Program under Grant NRF-2016R1D1A1B03930712.

References

- Abe, H., Sakamoto, H., Harada, K., 2000. A noncontact charger using a resonant converter with parallel capacitor of the secondary coil. *IEEE Trans. Indust. Appl.* 36 (2), 444–451.
- Ahmad, A., Alam, M.S., Chabaa, R., 2018. A comprehensive review of wireless charging technologies for electric vehicles. *IEEE Transact. Transport. Electrification* 4 (1), 38–63.
- Ahn, Seungyoung, 2013. “The All-Electric Car You Never Plug In” Published by IEEE Spectrum. Available from: < <https://spectrum.ieee.org/transportation/advanced-cars/the-allelectric-car-you-never-plug-in> > (accessed 17/04/2018).
- Amditis, A., Theodoropoulos, T., Brusaglino, G., Rizzo, R., Di Noia, L., Rodella, G., Oceano, A., 2017. Energy management optimization within the electric mobility system. 2017 6th International Conference on Clean Electrical Power (ICCEP). IEEE, pp. 110–116.
- Bansal, P., 2015. Charging of electric vehicles: technology and policy implications. *J. Sci. Pol. Govern.* 6 (1), 38.
- Bertsimas, D., Brown, D.B., Caramanis, C., 2011. Theory and applications of robust optimization. *SIAM Rev.* 53 (3), 464–501.
- Bi, Z., Kan, T., Mi, C.C., Zhang, Y., Zhao, Z., Keoleian, G.A., 2016. A review of wireless power transfer for electric vehicles: prospects to enhance sustainable mobility. *Appl. Energy* 179, 413–425.
- Bi, Z., Kleime, R., Keoleian, G.A., 2017. Integrated life cycle assessment and life cycle cost model for comparing plug-in versus wireless charging for an electric bus system. *J. Indust. Ecol.* 21 (2), 344–355.
- Bi, Z., Song, L., De Kleime, R., Mi, C.C., Keoleian, G.A., 2015. Plug-in vs. wireless charging: life cycle energy and greenhouse gas emissions for an electric bus system. *Appl. Energy* 146, 11–19.
- Birrell, S.A., Wilson, D., Yang, C.P., Dhadyalla, G., Jennings, P., 2015. How driver behaviour and parking alignment affects inductive charging systems for electric vehicles. *Transport. Res. Part C: Emerg. Technol.* 58, 721–731.
- Bludszuweit, H., 2016. Project victoria - the first spanish showcase for DWPT. In: 2016 FABRIC conference (Presentation), FABRIC.
- Brecher, A., Arthur, D., 2014. Review and Evaluation of Wireless Power Transfer (WPT) for Electric Transit Applications, Technical report.
- Chehab, N., 2016. Wireless Electric Charging: The Future of Plug-In Electric Vehicles is Going Cordless < <https://www.energy.gov/eere/articles/wireless-electric-charging-future-plug-electric-vehicles-going-cordless> > .
- Chen, F., Taylor, N., Kringos, N., 2015. Electrification of roads: opportunities and challenges. *Appl. Energy* 150, 109–119.
- Chen, L., Wu, M., Xu, X., 2012. The development and applications of charging/battery swap technologies for EVs. 2012 China International Conference on Electricity Distribution (CICED). IEEE, pp. 1–7.
- Chen, Z., He, F., Yin, Y., 2016. Optimal deployment of charging lanes for electric vehicles in transportation networks. *Transport. Res. Part B: Methodol.* 91, 344–365.
- Chen, Z., Liu, W., Yin, Y., 2017. Deployment of stationary and dynamic charging infrastructure for electric vehicles along traffic corridors. *Transport. Res. Part C: Emerg. Technol.* 77, 185–206.
- Cho, D.H., 2017. Regulatory and Safety Issues, The On-Line Electric Vehicle. Springer pp. 347–379.
- Choi, S.Y., Gu, B.W., Jeong, S.Y., Rim, C.T., 2015. Advances in wireless power transfer systems for roadway-powered electric vehicles. *IEEE J. Emerg. Select. Topics Power Electron.* 3 (1), 18–36.
- Chopra, S., Bauer, P., 2013. Driving range extension of ev with on-road contactless power transfer a case study. *IEEE Trans. Indust. Electron.* 60 (1), 329–338.
- Church, R., Velle, C.R., 1974. The maximal covering location problem. *Pap. Reg. Sci.* 32 (1), 101–118.
- Cirimele, V., Freschi, F., Mitolo, M., 2016. Inductive power transfer for automotive applications: state-of-the-art and future trends. In: Industry Applications Society Annual Meeting, 2016 IEEE. IEEE, pp. 1–8.
- Covic, G.A., Boys, J.T., 2013. Modern trends in inductive power transfer for transportation applications. *IEEE J. Emerg. Select. Topics Power Electron.* 1 (1), 28–41.
- de Blas, J., 2017. Fabric first results and overview. In: IV European Electric Vehicle Congress (Presentation). CEVE.
- Deflorio, F., Castello, L., 2015. Assessing the performance of a charge-while-driving system in urban arterial roads: insight from a microsimulation model. *IET Intell. Transp. Syst.* 9 (5), 505–514.
- Deflorio, F., Castello, L., 2017. Dynamic charging-while-driving systems for freight delivery services with electric vehicles: traffic and energy modelling. *Transport. Res. Part C: Emerg. Technol.* 81, 342–362.
- Deflorio, F., Guglielmi, P., Pinna, I., Castello, L., Marfull, S., 2015a. Modeling and analysis of wireless charge while driving operations for fully electric vehicles. *Transport. Res. Proc.* 5, 161–174.
- Deflorio, F.P., Castello, L., Pinna, I., Guglielmi, P., 2015b. charge while driving for electric vehicles: road traffic modeling and energy assessment. *J. Mod. Power Syst. Clean Energy* 3 (2), 277–288.
- Emadi, A., Rajashekara, K., Williamson, S.S., Lukic, S.M., 2005. Topological overview of hybrid electric and fuel cell vehicular power system architectures and configurations. *IEEE Trans. Vehic. Technol.* 54 (3), 763–770.
- Empey, D., 1994. Roadway Powered Electric Vehicle Project: Track Construction and Testing Program. Phase 3D. California Path Program. Institute of Transportation

- Studies, University of California, Berkeley.
- Filho, P., Suh, I.-S., 2013. Implementation cost comparison of electric vehicle energy replenishment technologies for public transit bus systems. *Transport. Res. Rec.: J. Transport. Res. Board* (2352), 11–19.
- Fisher, T.M., Farley, K.B., Gao, Y., Bai, H., Tse, Z.T.H., 2014. Electric vehicle wireless charging technology: a state-of-the-art review of magnetic coupling systems. *Wirel. Power Transfer* 1 (2), 87–96.
- Fisk, C., 1980. Some developments in equilibrium traffic assignment. *Transport. Res. Part B: Methodol.* 14 (3), 243–255.
- FKA, 2015. Unplugged - interoperable inductive charging for electric vehicles. In: FABRIC Conference, Brussels (Presentation). FABRIC.
- Foley, A., Winning, I., Gallachóir, B.Ó., 2010. State-of-the-art in electric vehicle charging infrastructure. In: 2010 IEEE Vehicle Power and Propulsion Conference (VPPC). IEEE, pp. 1–6.
- Foot, A., Onar, O.C., 2017. A review of high-power wireless power transfer. 2017 IEEE Transportation Electrification Conference and Expo (ITEC). IEEE, pp. 234–240.
- Fuller, M., 2016. Wireless charging in California: range, recharge, and vehicle electrification. *Transport. Res. Part C: Emerg. Technol.* 67, 343–356.
- García-Vázquez, C.A., Llorens-Iborra, F., Fernández-Ramírez, L.M., Sánchez-Sainz, H., Jurado, F., 2017. Comparative study of dynamic wireless charging of electric vehicles in motorway, highway and urban stretches. *Energy* 137, 42–57.
- Gil, A., Taiber, J., 2014. A literature review in dynamic wireless power transfer for electric vehicles: technology and infrastructure integration challenges. In: *Sustainable Automotive Technologies 2013*. Springer, pp. 289–298.
- Gill, J.S., Bhavsar, P., Chowdhury, M., Johnson, J., Taiber, J., Fries, R., 2014. Infrastructure cost issues related to inductively coupled power transfer for electric vehicles. *Proc. Comp. Sci.* 32, 545–552.
- Green II, R.C., Wang, L., Alam, M., 2011. The impact of plug-in hybrid electric vehicles on distribution networks: a review and outlook. *Renew. Sustain. Energy Rev.* 15 (1), 544–553.
- Green Target, 2016. Who Killed The Electric Highway? < <https://greentarget.com/2016/09/20/who-killed-the-electric-highway/> > .
- He, F., Yin, Y., Lawphongpanich, S., 2014. Network equilibrium models with battery electric vehicles. *Transport. Res. Part B: Methodol.* 67, 306–319.
- He, F., Yin, Y., Zhou, J., 2013. Integrated pricing of roads and electricity enabled by wireless power transfer. *Transport. Res. Part C: Emerg. Technol.* 34, 1–15.
- Helber, S., Broihan, J., Jang, Y.J., Hecker, P., Feuerle, T., 2018. Location planning for dynamic wireless charging systems for electric airport passenger buses. *Energies* 11 (2), 258.
- Highway England, 2015. Feasibility Study: Powering Electric Vehicles on England's Major Roads. Highways England Company (28(07)).
- Hodgson, M.J., 1990. A flow-capturing location-allocation model. *Geograph. Anal.* 22 (3), 270–279.
- Hong, E.-P., Park, G.-J., 2010. Design information management of an on-line electric vehicle using axiomatic design. *SAE Int. J. Mater. Manufact.* 3 (2010-01-0279), 133–141.
- Hussain, R., Kim, D., Nogueira, M., Son, J., Tokuta, A.O., Oh, H., 2015a. Pbf: A New Privacy-Aware Billing Framework for Online Electric Vehicles with Bidirectional Auditability, arXiv preprint [arXiv:1504.05276](https://arxiv.org/abs/1504.05276).
- Hussain, R., Kim, D., Nogueira, M., Son, J., Tokuta, A., Oh, H., 2015b. A new privacy-aware mutual authentication mechanism for charging-on-the-move in online electric vehicles. In: 2015 11th International Conference on Mobile Ad-hoc and Sensor Networks (MSN). IEEE, pp. 108–115.
- Hwang, I.H., Jang, Y.J., Choi, H., Meixiang, J., Kim, S., Moon, I.-H., 2016. Overhead shuttle design for a flat panel display production line considering the contactless power supply capacity. In: Proceedings of the 2016 International Symposium on Semiconductor Manufacturing Intelligence (ISMI2016), International Symposium on Semiconductor Manufacturing Intelligence.
- Hwang, I., Jang, Y.J., Ko, Y.D., Lee, M.S., 2017. System optimization for dynamic wireless charging electric vehicles operating in a multiple-route environment. *IEEE Trans. Intell. Transport. Syst. Article-in-Advance* 1–18.
- IEC, TC 69, 2017. Electric Road Vehicles and Electric Industrial Trucks < http://www.iec.ch/dyn/www/?p=103:23:0:::FSP_ORG_ID,FSP_LANG_ID:125525 > .
- IEEE ISTO, 2017. Wireless Power Consortium Program. < <http://www.ieee-isto.org/member-programs/wirelesspower-consortium> > .
- IEEE Standards, 2017. Electric Vehicle Wireless Power Transfer < http://standards.ieee.org/about/sasb/iccom/IC13-002-03_Electric_Vehicle_Wireless_Power_Transfer.pdf > .
- Imura, T., Hori, Y., 2011. Maximizing air gap and efficiency of magnetic resonant coupling for wireless power transfer using equivalent circuit and Neumann formula. *IEEE Trans. Indust. Electron.* 58 (10), 4746–4752.
- IPT Technology Official Website, 2017 < <http://www.ipt-technology.com> > .
- ISO/AWI PAS 19363, 2017. Electrically Propelled Road Vehicles Magnetic Field Wireless Power Transfer Safety and Interoperability Requirements < http://www.iso.org/iso/home/store/catalogue_tc/catalogue_detail.htm?csnumber=64700 > .
- Jang, Y.J., Choi, G.H., Kim, S.I., 2005. Modeling and analysis of stocker system in semiconductor and LCD FAB. In: IEEE International Symposium on Semiconductor Manufacturing, 2005, ISSM 2005. IEEE, pp. 273–276.
- Jang, Y.J., Jeong, S., Ko, Y.D., 2015. System optimization of the on-line electric vehicle operating in a closed environment. *Comp. Indust. Eng.* 80, 222–235.
- Jang, Y.J., Jeong, S., Lee, M.S., 2016. Initial energy logistics cost analysis for stationary, quasi-dynamic, and dynamic wireless charging public transportation systems. *Energies* 9 (7), 483.
- Jang, Y.J., Suh, E.S., Kim, J.W., 2016. System architecture and mathematical models of electric transit bus system utilizing wireless power transfer technology. *IEEE Syst. J.* 10 (2), 495–506.
- Jeong, S., Jang, Y.J., Kum, D., 2015. Economic analysis of the dynamic charging electric vehicle. *IEEE Trans. Power Electron.* 30 (11), 6368–6377.
- Jung, G.H., 2017. Installation of Road-Embedded Power Cable, The On-line Electric Vehicle. Springer pp. 159–170.
- Kalialakis, C., Collado, A., Georgiadis, A., 2016. Regulations and standards for wireless power transfer systems. In: *Wireless Power Transfer Algorithms, Technologies and Applications in Ad Hoc Communication Networks*. Springer, pp. 161–181.
- Kalialakis, C., Georgiadis, A., 2014. The regulatory framework for wireless power transfer systems. *Wirel. Power Transfer* 1 (2), 108–118.
- Kim, J., Kim, J., Kong, S., Kim, H., Suh, I.-S., Suh, N.P., Cho, D.-H., Kim, J., Ahn, S., 2013. Coil design and shielding methods for a magnetic resonant wireless power transfer system. *Proc. IEEE* 101 (6), 1332–1342.
- Kim, J., Song, I., Choi, W., 2015. An electric bus with a battery exchange system. *Energies* 8 (7), 6806–6819.
- Ko, Y.D., Jang, Y.J., 2013. The optimal system design of the online electric vehicle utilizing wireless power transmission technology. *IEEE Trans. Intell. Transport. Syst.* 14 (3), 1255–1265.
- Ko, Y.D., Jang, Y.J., 2018. Efficient design of an operation profile for wireless charging electric tram systems. *Comp. Indust. Eng.* Available from: < <https://www.sciencedirect.com/science/article/abs/pii/S0360835218301335> > (accessed 17/04/2018).
- Ko, Y.D., Jang, Y.J., Lee, M.S., 2015. The optimal economic design of the wireless powered intelligent transportation system using genetic algorithm considering nonlinear cost function. *Comput. Indust. Eng.* 89, 67–79.
- Lechner, E.H., Shladover, S.E., Lashkari, K., Empey, D.M., 1993. Inductive Energization System and Method for Vehicles. US Patent 5207304.
- Lee, M.S., Jang, Y.J., 2017. Charging infrastructure allocation for wireless charging transportation system. In: *International Conference on Management Science and Engineering Management*. Springer, pp. 1630–1644.
- Li, J.-Q., 2016. Battery-electric transit bus developments and operations: a review. *Int. J. Sustain. Transport.* 10 (3), 157–169.
- Li, S., Mi, C.C., 2015. Wireless power transfer for electric vehicle applications. *IEEE J. Emerg. Select. Topics Power Electron.* 3 (1), 4–17.
- Limb, B.J., Bradley, T.H., Crabb, B., Zane, R., McGinty, C., Quinn, J.C., 2016. Economic and environmental feasibility, architecture optimization, and grid impact of dynamic charging of electric vehicles using wireless power transfer. In: 6th Hybrid and Electric Vehicles Conference (HEVC 2016). IET, pp. 1–6.
- Liu, H., Wang, D.Z., 2017. Locating multiple types of charging facilities for battery electric vehicles. *Transport. Res. Part B: Methodol.* 103, 30–55.
- Liu, Z., Song, Z., 2017. Robust planning of dynamic wireless charging infrastructure for battery electric buses. *Transport. Res. Part C: Emerg. Technol.* 83, 77–103.
- Lukic, S., Pantic, Z., 2013. Cutting the cord: static and dynamic inductive wireless charging of electric vehicles. *IEEE Electrific. Magaz.* 1 (1), 57–64.
- Mak, H.-Y., Rong, Y., Shen, Z.-J.M., 2013. Infrastructure planning for electric vehicles with battery swapping. *Manage. Sci.* 59 (7), 1557–1575.
- Manshadi, S.D., Khodayar, M.E., Abdelghany, K., Uster, H., 2017. Wireless charging of electric vehicles in electricity and transportation networks. *IEEE Transact. Smart*

- Grid. (available online).
- Miller, J.M., Jones, P.T., Li, J.-M., Onar, O.C., 2015. Ornl experience and challenges facing dynamic wireless power charging of eV's. *IEEE Circuits and Systems Magazine* 15 (2), 40–53.
- Miller, J.M., Onar, O.C., Chinthavali, M., 2015. Primary-side power flow control of wireless power transfer for electric vehicle charging. *IEEE J. Emerg. Select. Topics Power Electron.* 3 (1), 147–162.
- Mohamed, A.A., Lashway, C.R., Mohammed, O., 2017. Modeling and feasibility analysis of quasi-dynamic WPT system for EV applications. *IEEE Transact. Transport. Electrification* 3 (2), 343–353.
- Möller, C., 2017. Carbon Neutral Road Transportation: An Assessment of the Potential of Electrified Road Systems. Available from: < <http://www.diva-portal.org/smash/record.jsf?pid=diva2%3A1127479&dsid=-7432> > (accessed 17/4/2018).
- Mouhrim, N., Alaoui, A.E.H., Boukachour, J., 2016. Optimal allocation of wireless power transfer system for electric vehicles in a multipath environment. 2016 3rd International Conference on Logistics Operations Management (GOL). IEEE, pp. 1–7.
- Musavi, F., Edington, M., Eberle, W., 2012. Wireless power transfer: a survey of eV battery charging technologies. In: 2012 IEEE Energy Conversion Congress and Exposition (ECCE). IEEE, pp. 1804–1810.
- Nguyen, S., Dupuis, C., 1984. An efficient method for computing traffic equilibria in networks with asymmetric transportation costs. *Transport. Sci.* 18 (2), 185–202.
- Nicolaides, D., Miles, J., 2015. Wireless electric charge-on-the-move: a sustainability appraisal of the potential for the UK transport application. *J. Multidisc. Eng. Sci. Technol* 2 (8), 2238–2246.
- Nie, Y.M., Ghamami, M., 2013. A corridor-centric approach to planning electric vehicle charging infrastructure. *Transport. Res. Part B: Methodol.* 57, 172–190.
- Off road trials for electric highways technology, 2015 < <https://www.gov.uk/government/news/off-road-trials-for-electric-highways-technology> > .
- OLEV Annual Progress Report 2010 (System division), 2010. KAIST OLEV Report 1.
- Onar, O.C., Campbell, S.L., Seiber, L.E., White, C.P., Chinthavali, M.S., Tang, L., Chambon, P.H., Ozpineci, B., Smith, D.E., 2016. Oak Ridge National Laboratory Wireless Charging of Electric Vehicles-Crada Report, *Technical report*. Oak Ridge National Laboratory (ORNL), Oak Ridge, TN (United States). National Transportation Research Center (NTRC); Power Electronics and Electric Machinery Research Facility.
- Onar, O.C., Miller, J.M., Campbell, S.L., Coomer, C., White, C.P., Seiber, L.E., 2013. Oak ridge national laboratory wireless power transfer development for sustainable campus initiative. In: 2013 IEEE Transportation Electrification Conference and Expo (ITEC). IEEE, pp. 1–8.
- Palen, J., Coifman, B., Sun, C., Ritchie, S.G., Varaiya, P., 2000. California partners for advanced transit and highways (path) enhanced loop-based traffic surveillance program. *ITS Quart.* 8 (4).
- Pantic, Z., Bai, S., Lukic, S.M., 2009. Inductively coupled power transfer for continuously powered electric vehicles. In: Vehicle Power and Propulsion Conference, 2009, VPPC'09, IEEE. IEEE, pp. 1271–1278.
- Park, J.H., Jeong, Y.H., 2017. *The Economics of Wireless Charging on the Road, The On-line Electric Vehicle*. Springer pp. 329–345.
- Pereirinha, P.G., Trovão, J.P., Santos, V., 2016. Electric propulsion vehicles standardization: where are we? In: International Conference on Modern Electrical Power Engineering, ICMEPE-2016. Las Palmas de Gran Canaria, Spain.
- Riemann, R., Wang, D.Z., Busch, F., 2015. Optimal location of wireless charging facilities for electric vehicles: flow-capturing location model with stochastic user equilibrium. *Transport. Res. Part C: Emerg. Technol.* 58, 1–12.
- Rim, C.T., Mi, C., 2017. *Wireless Power Transfer for Electric Vehicles and Mobile Devices*. John Wiley & Sons.
- Rim, C.T., Mi, C., n.d. History of RPEVs, Wireless Power Transfer for Electric Vehicles and Mobile Devices, pp. 161–208.
- SAE J2954 Overview and Path Forward, 2017. < http://www.sae.org/smartgrid/sae-j2954-status_1-2012.pdf > .
- Sarker, A., Li, Z., Kolodzey, W., Shen, H., 2017. Opportunistic energy sharing between power grid and electric vehicles: a game theory-based pricing policy. In: 2017 IEEE 37th International Conference on Distributed Computing Systems (ICDCS). IEEE, pp. 1197–1207.
- Sarker, M.R., Pandžić, H., Ortega-Vazquez, M.A., 2015. Optimal operation and services scheduling for an electric vehicle battery swapping station. *IEEE Trans. Power Syst.* 30 (2), 901–910.
- Shekhar, A., Prasanth, V., Bauer, P., Bolech, M., 2016. Economic viability study of an on-road wireless charging system with a generic driving range estimation method. *Energies* 9 (2), 76.
- Shin, J., Shin, S., Kim, Y., Ahn, S., Lee, S., Jung, G., Jeon, S.-J., Cho, D.-H., 2014. Design and implementation of shaped magnetic-resonance-based wireless power transfer system for roadway-powered moving electric vehicles. *IEEE Trans. Indust. Electron.* 61 (3), 1179–1192.
- Shinohara, N., 2011. Power without wires. *IEEE Microw. Magaz.* 12 (7), S64–S73.
- Shladover, S.E., 2007. Path at 20th history and major milestones. *IEEE Trans. Intell. Transport. Syst.* 8 (4), 584–592.
- Stamati, T.-E., Bauer, P., 2013. On-road charging of electric vehicles. In: Transportation Electrification Conference and Expo (ITEC), 2013 IEEE. IEEE, pp. 1–8.
- Suh, N.P., 2012. Fundamentals of design and deployment of large complex systems: Olev, mh, and mixalloy. *J. Integ. Des. Process Sci.* 16 (3), 7–28.
- Suh, N.P., Cho, D.H., 2017a. *Axiomatic Design in the Design of OLEV, The On-line Electric Vehicle*. Springer pp. 59–80.
- Suh, N.P., Cho, D.H., 2017b. Making the Move: From Internal Combustion Engines to Wireless Electric Vehicles, *The On-line Electric Vehicle*. Springer pp. 3–15.
- Suh, N.P., Cho, D.H., 2017c. *The On-Line Electric Vehicle: Wireless Electric Ground Transportation Systems*.
- Suh, N.P., Cho, D.H., 2017d. *Wireless Power Transfer for Electric Vehicles, The On-line Electric Vehicle*. Springer pp. 17–34.
- Suh, N.P., Cho, D.-H., Rim, C.T., 2011. Design of On-Line Electric Vehicle (olev), Global Product Development. Springer pp. 3–8.
- Tavakoli, R., Jovicic, A., Bohm, R., Pantic, Z., 2016. Hardware design for dynamic wireless charging of an electric bus. In: SELECT Annual Meeting and Technology Showcase (Poster), SELECT, pp. 1–6.
- Unplugged Fianl Report, 2015. Unplugged Final Report. Technical report.
- Ushijima-Mwesigwa, H., Khan, M., Chowdhury, M.A., Safro, I., 2017. Optimal Installation for Electric Vehicle Wireless Charging Lanes, arXiv preprint arXiv:1704.01022.
- Valtchev, S.S., Baikova, E.N., Jorge, L.R., 2012. Electromagnetic field as the wireless transporter of energy. *Facta universitatis-series: Electron. Energet.* 25 (3), 171–181.
- Wang, Y.-W., Lin, C.-C., 2009. Locating road-vehicle refueling stations. *Transport. Res. Part E: Logist. Transport. Rev.* 45 (5), 821–829.
- WAVE Official Website, 2017. < <http://www.waveipt.com/> > .
- Wireless Charging Road for Electric Buses Will be Built in Israel, 2017 < <http://bigthink.com/design-for-good/wireless-charging-road-for-electric-busses-will-be-built-in-israel> > .
- Wu, H.H., Gilchrist, A., Sealy, K.D., Bronson, D., 2012. A high efficiency 5 kw inductive charger for eVs using dual side control. *IEEE Trans. Indust. Inf.* 8 (3), 585–595.
- Wu, H.H., Gilchrist, A., Sealy, K., Israelsen, P., Muhs, J., 2011. A review on inductive charging for electric vehicles. In: 2011 IEEE International Electric Machines & Drives Conference (IEMDC). IEEE, pp. 143–147.
- Xie, H., Ding, T., Liu, S., Bie, Z., 2016. Sequential power flow simulation of integrated dynamic wireless power transfer systems. In: Power and Energy Society General Meeting (PESGM). IEEE, pp. 1–5.
- Xu, B., et al., 2013. Degradation-Limiting Optimization of Battery Energy Storage Systems Operation.
- Yilmaz, M., Krein, P.T., 2013. Review of battery charger topologies, charging power levels, and infrastructure for plug-in electric and hybrid vehicles. *IEEE Trans. Power Electron.* 28 (5), 2151–2169.
- Yoon, U., 2017. Electrification of Other Transportation Systems. *The On-line Electric Vehicle*. Springer pp. 261–268.