

The MARVEL EU project: A social constructivist approach to remote experimentation

*José M. Ferreira*¹, *Dieter Mueller*²

FEUP (University of Porto), ARTEC (Bremen University)

Key words: *Remote engineering, social constructivism, mixed-reality*

Abstract:

This paper proposes a conceptual model where experimentation is envisaged as a tool to achieve instructional objectives via social constructivist learning methods. Remote experiments are embedded in an e-learning framework that supports the acquisition of theoretical concepts, communication via video-conferencing, equipment interface panels, and the management tools to support this architecture. Each remote experiment is presented as a broader activity (workshop activity) meant to achieve pre-defined learning goals, where collaborative actions and peer-review activities are at the basis of the social constructivist learning model. The outcome of these activities is itself a learning object that provides evidence that the learning goals were achieved.

1 Introduction

Remote experimentation has been the subject of many publications and R&D projects during recent years. However, most of the projects that were carried out so far in this area were essentially of a technical nature, leaving the pedagogical aspects to be addressed separately. The very nature of remote experimentation (e.g. why would we want to do it?) is frequently forgotten, and such questions as the pros and cons of remote experimentation versus simulation, are seldomly addressed.

The words in the title of CSCL (Computer Support for *Collaborative Learning*) and CSCW (Computer Supported *Cooperative Work*) conferences [1] may be used to illustrate the relative ambiguity of (remote or local) workbench activities: are they *collaborative* activities, where the team members carry out *the same* tasks in parallel (the typical learning scenario, where each individual must achieve the same learning objectives), or *cooperative* activities, which are characterised by splitting the work in complementary tasks among the various team members (the typical working scenario, where each individual is not supposed to repeat what other members are doing)? As it happens, there will be occasions when the learning objectives will predominate in a remote experiment, and other occasions when it will represent a service provided to companies or institutions that cannot afford the equipment required to carry out the experiment. The wider scenario underlying remote experimentation still has much room for discussion and R&D work, particularly in what concerns the pedagogical framework where such activities are incorporated.

This paper presents the work that is being done in this area within the MARVEL EU project (Virtual Laboratory in Mechatronics: Access to Remote and Virtual e-Learning),

with an emphasis on workbench access via the web [2]. We start with an overview of remote experimentation, using it as an introduction to address its underlying pedagogical aspects. A social constructivist approach to remote experimentation is then presented, followed by a description of the remote experimentation model within MARVEL. Before concluding, a case study is presented to illustrate the proposed approach in practice.

2 Overview of remote experimentation

For the purposes addressed in this paper, *remote experimentation* may be illustrated as shown in figure 1, and is defined as *an activity where an individual (alone or as part of a team) uses a communication network to carry out a laboratory work assignment*. This definition enables a wide variety of scenarios, including one where the participants and the workbench are located in the same room. The distance factor is actually not relevant, since what qualifies an experiment as remote is the fact that one or more of the participants *have to use* a communication network in order to carry it out (and indeed the equipment used in the experiment may be distributed among various locations).

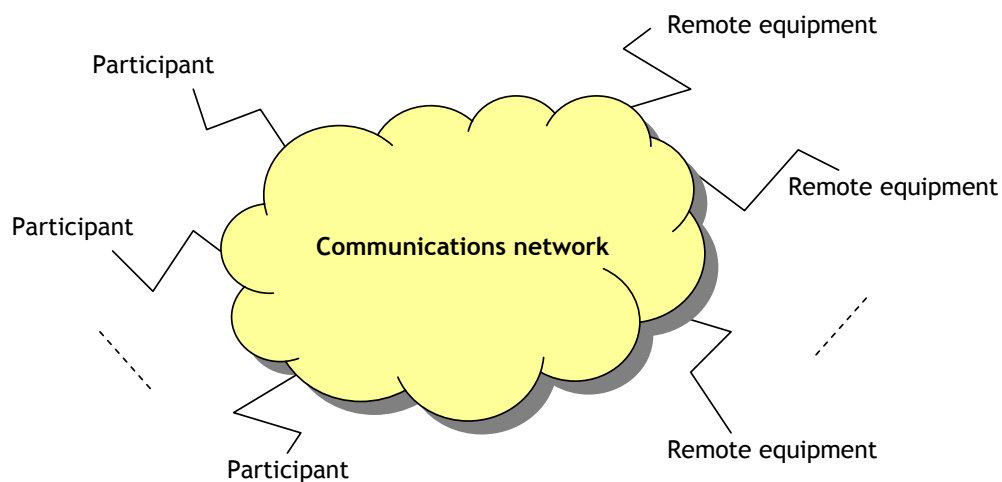

Fig. 1: Representation of a general remote experimentation scenario.

The typical scenario, if one may use such an expression, corresponds to several students that use the web to access the campus from their homes. On most occasions, their objective consists of carrying out a work assignment that is included in their curricular activities. This is actually the scenario that underlies the work described in this paper, and as such we will consider the participants as students and the remote experiments as instructional activities. However, remote experimentation is not necessarily an academic activity. Another possible scenario consists of an institution that provides remote access to some form of equipment that may be too expensive to be acquired by an individual or even a small company (e.g. an electron microscope). From the technical point of view, these two scenarios are exactly equivalent: one or more participants need to access a technical facility via a communications network [3, 4, 5].

Remote experimentation has been a buzzword since at least the second half of the 1990s, and it is not difficult to find publications and R&D projects that address this area. A proper taxonomy of remote experimentation has yet to be devised, but one may easily build a list of possible classification criteria, such as:

- Area of activity: mechanical engineering, electronics, chemistry, basic science, etc.
- Duration of the experiment: a typical electronics experiment may last for 15 minutes to one hour, but one may think of experiments in physics that may last for well less than one second.
- Repeatability: some experiments may be repeated many times using exactly the same resources (e.g. an electronics experiment), while others may require periodic maintenance work in the remote lab (e.g. chemistry experiments), or even be one-time experiments (when the experiment destroys all or part of its resources).

These are but a few examples, which will impact on the technical infrastructure supporting remote experimentation. Experiments based on interactive procedures, where every action of the student produces some visible effect, which in turn helps him/her to decide what to do next, are of course not possible in the case of experiments that last only for a fraction of a second. In such cases, the students will simply specify the experiment parameters and trigger its execution. Whatever the case, the following building blocks will be required to support remote experimentation:

- A synchronous communication tool to enable the students to exchange information in real time (e.g. video-conferencing over the web).
- Instrumentation panels to access the remote equipment (for control / observation purposes).
- A management application that enables scheduling / booking of resources (a given experiment can only be carried out by one group at each time).
- A lab script that identifies the experiment objectives (including the learning goals) and procedures.
- A learning content that constitutes the theoretical background required to successfully achieve the learning objectives served by the experiment.

Most of the literature available addresses only a subset of the building blocks referred above, and in many cases the work described does not go beyond the technical aspects involved in controlling / monitoring some form of remote equipment. An integrated solution merging technical and pedagogical frameworks to support remote experimentation is therefore yet a novel contribution to this area.

3 Pedagogical issues

Why should we be interested in remote experimentation? If a proper explanation may be found (i.e. if remote experimentation brings a clearly identifiable added-value), a second question has to be asked: *how* should it be carried out? (e.g. how do we wish the students to perceive remote experimentation?)

In relation to the first question, the answer is very straightforward: *because remote experimentation provides a simple way to consolidate knowledge*. The end goal is therefore *to do something*, based on the common sense statement saying that the best way to learn about something is actually *to do it*, instead of *reading or hearing* about it. Of course one may argue that simulation is a viable alternative, and much cheaper. The fact is that cheaper simulation environments, at the current state of technology, will in most cases be much further away from reality. On the other hand, they tend to model relatively narrow application areas, and therefore it is not easy to set up comprehensive simulation environments to represent multidisciplinary experiments. If one wishes to set an experiment where an 80C51 microcontroller is used to control a simple robotic manipulator used to carry out elementary pick-and-place tasks, a full simulation environment will be more troublesome to set up than the real target hardware. This is

basically the main reason why we want our students to go through hands-on workbench assignments, although there are of course other reasons, such as the assessment of skills required by professional certification bodies. In the latter case the student will have to be present in the lab. In all other cases, remote experimentation brings an added-value in terms of flexibility: workbench assignments may now be carried out from anywhere at anytime.

As to *how* should a remote experiment be carried out (or at least perceived by the student), the answer is much less straightforward, namely because its pedagogic implications are not easy to foresee. We may try to replicate the “real workbench experience”, but that is not necessarily an objective. The use of an emerging technology for educational purposes is not enough by itself to ensure pedagogic effectiveness. Innovative (or at least) appropriate teaching and learning concepts have to be devised in order to reach our ultimate objective: to *facilitate learning*. We should also take into account that remote experimentation is not a full replication of reality, a fact which in itself has pros and cons: we can more easily avoid catastrophic situations, but on the other hand the students do not have the haptic experience that is conveyed by manipulating the experiment in the lab (e.g. they will not assemble an electronic circuit to be used in an electronics experiment). We frequently tend to innovate in the technology settings, but replicate traditional ways of working — remote experimentation *does not have to be* a replication of the real lab experience. While helping to overcome some cultural barriers that may hamper the acceptance of new procedures, innovation at the methodological level may also maximise the pedagogical benefits of experimentation via the web. With this respect, it is particularly interesting to establish a relation between remote experimentation and social constructivism [6], a theory of teaching and learning that constitutes the foundation of Moodle, a course management system that is finding an exceptional acceptance within the academic community [7].

4 Social constructivism and remote experimentation

Most e-learning packages are based on specific models of teaching and learning, where the instructor is regarded as a facilitator in the learning process, helping the students to build knowledge by using the web and other resources in an exploratory manner. Of course that an instructor may still use an e-learning package as a simple content aggregation portal [8], using a plain instructivist model to deliver his/her courses, and as such it is never too much to reinforce the need for good pedagogical practices.

The Moodle e-learning package provides the technological and pedagogical framework supporting the work presented in this paper. Moodle is a course management system offered to the public as an Open Source software package (it may be downloaded, used, modified and distributed under the terms of the GNU General Public License). It runs on any system that supports PHP (including Unix, Linux, Windows, etc.) and uses a single database (MySQL and PostgreSQL are best supported). An interesting aspect of this e-learning platform is that its community of supporters emphasise that Moodle has *a strong grounding in social constructivist pedagogy* [9].

As commonly accepted within the Moodle community, *social constructivism* refers to “*a social group constructing things for one another, collaboratively creating a small culture of shared artifacts with shared meanings*”. This statement actually highlights the most important aspects underlying remote experiments, and could hardly be better phrased if it was originally planned to refer to the main subject of this paper: remote

experimentation requires an active role from the students (*constructing*, also in the sense of learning by doing and exploring), who must share their knowledge and skills (*collaboratively*) to carry out a work assignment where some form of remote equipment is used to reach a common understanding of reality (*shared artifacts with shared meanings*).

Moodle makes available several types of resources to build course contents and support learning activities. Among such resources is one called *workshop*, which is used primarily to guide students through the various phases involved in producing and delivering contents using peer review techniques. A workshop activity comprises several phases distributed along a timeline set by the teacher, as illustrated in figure 2. Each student is required to go through a sequence of tasks that include the development and delivery of documents and the assessment of other students' documents. At the end, a final report / document is delivered and evaluated according to a given grading strategy (there are several strategies available for this purpose).

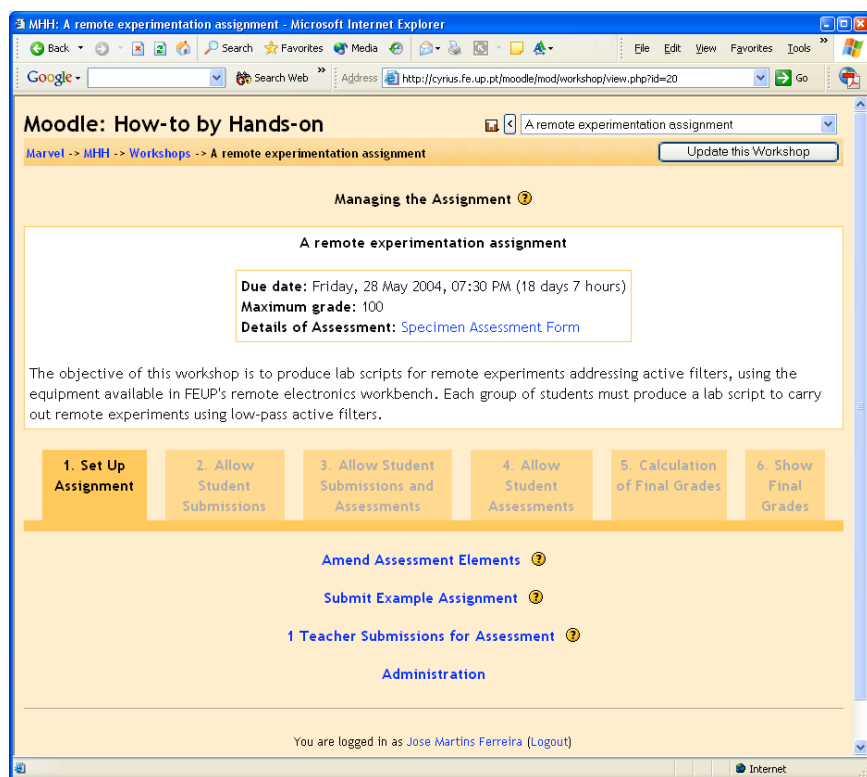

Fig. 2: A workshop activity within Moodle.

The workshop activity is indeed a very appropriate way of building remote experimentation work assignments, if one wishes to use social constructivism as a pedagogical framework to build knowledge via experimentation (either remote or local). Of course the remaining resources made available by Moodle will be used to support the theoretical background required to achieve the learning objectives, e.g. the *Lesson* resource may be used to provide a set of lecture notes with self-assessment quizzes able to guide the students through the initial knowledge building stages.

In the MARVEL EU project, we follow a social constructivist approach to learn via remote experimentation. A preferred way to achieve this objective is by asking the students to develop remote experimentation scripts for other students, as will be described in the following section.

5 Remote experimentation within MARVEL

MARVEL is an education and training project funded by the European Commission's Leonardo da Vinci programme. The aim of MARVEL is to implement and evaluate learning environments for Mechatronics in Vocational Training, that allow students ubiquitous online-access to physical workshops and laboratory facilities from remote places. The workplan covers concepts that merge real and virtual, as well as local and remote worlds in real time. MARVEL will produce evaluated working examples of remotely accessible practical environments, together with supporting e-learning and student assessment material, for the following application fields: robotics, modular production systems and process control. This includes the creation of actual demonstration models (learning scenarios and experimentation environments) in partner institutions and industry for evaluation purposes. With a duration of 30 months (ending in April of 2005), MARVEL brings together partners from Germany, Portugal, Scotland, Greece and Cyprus (with an external partner in Switzerland). The main target groups of MARVEL are students in vocational education and training in Mechatronics, and the main teaching subjects are system control, maintenance, process monitoring, automation technology of networked mechatronic plant and machinery on the basis of remote techniques (tele-services).

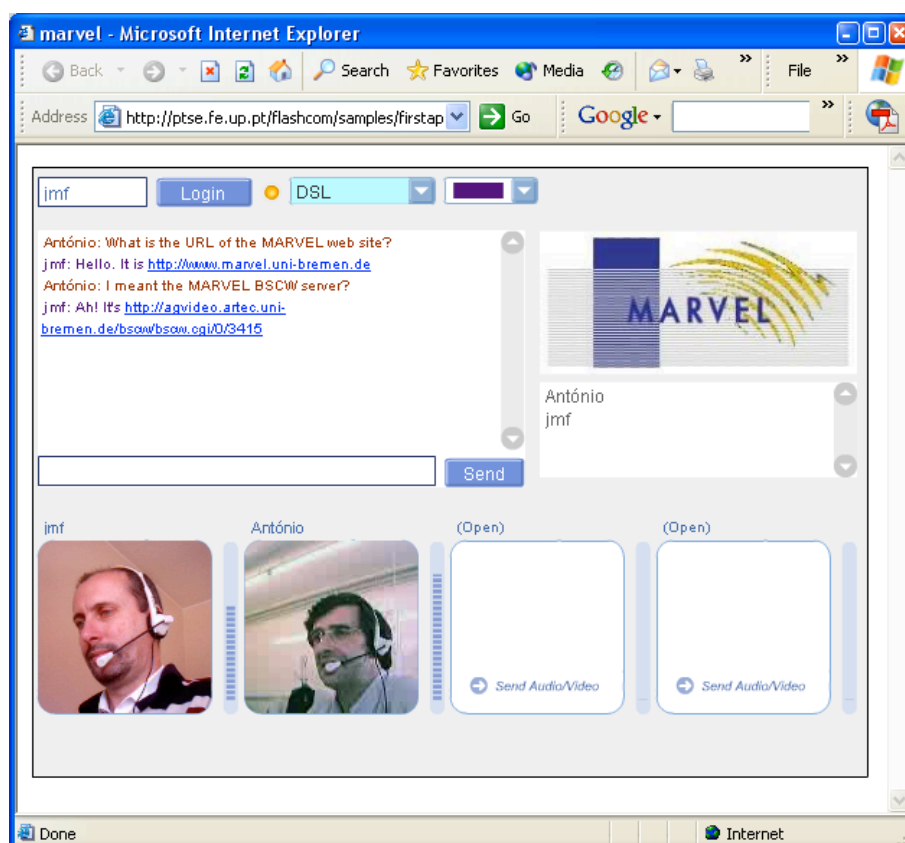

Fig. 3: The MARVEL video-conferencing room.

In what concerns remote experimentation, the MARVEL framework comprises the following modules:

- A Flash Communications server to support collaborative learning via video-conferencing, illustrated in figure 3.
- A proprietary scheduling / booking application that enables the students to reserve one-hour slots in the remote lab resources, illustrated in figure 4.
- An underlying e-learning package that integrates the modules referred above and all pedagogical contents that are necessary to carry out the required remote experiments.

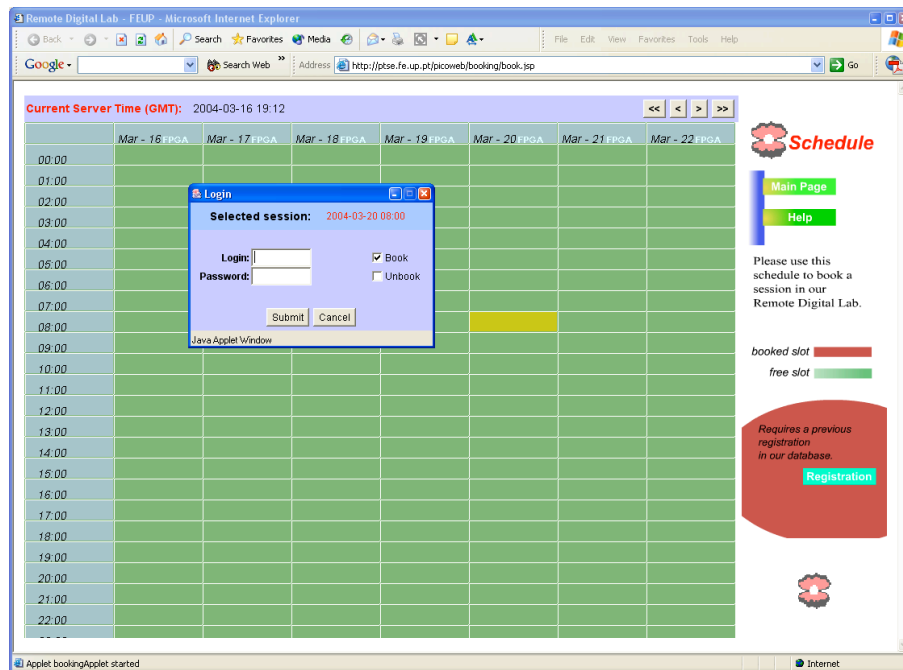

Fig. 4: The scheduling / booking application used to reserve time-slots in the remote lab.

Moodle is the preferred choice due to the social constructivist pedagogy that lies beneath this e-learning package, but any other course management system may in fact be used. A further advantage of Moodle is its open nature, enabling anyone to add features or suggest modifications to the community of programmers that support its development. A typical MARVEL remote experimentation scenario might be summarised as follows:

- The instructor drafts the meta-script description that will be used by the students to start their work and builds a corresponding *workshop* activity within the corresponding Moodle course (including the definition of deadlines and grading schemes).
- The remote lab equipment is set up to support the practical tasks required from the students, and the corresponding interface panels are developed (e.g. using a set of PXI modules and the corresponding LabView scripts).
- The instructor presents to each group of students the work to be done and the milestones and expected deliverables.
- The work of the students is initiated and the instructor supports and supervises its development, assessing the intermediate documents and deciding when to move on to the next phase of the workshop.

The two last steps may take place face-to-face or online using the video-conferencing server. It is assumed that the background theoretical contents are made available within

the same Moodle course, namely in the form of other Moodle activities, such as lessons, quizzes, assignments, a forum, etc.

The sequence above is actually more than a remote experiment, and might better be regarded as a *learning activity with an embedded remote experiment*. The learning goal was stated in the meta-script provided by the instructor and the social constructivist approach ensures that the students will at the end *provide evidence* that this learning goal was achieved.

6 Case study: characterisation of active filters

The case study presented in this section is meant to illustrate the social constructivist approach proposed, and also the tools and the environment that are used by the students when carrying out remote experiments. The application domain selected for this specific example was the characterisation of active filters (in simple terms, an ideal filter is an electronic circuit where the frequency of the input signal dictates whether it is passed on to the output or blocked), and the technical setup is illustrated in figure 5.

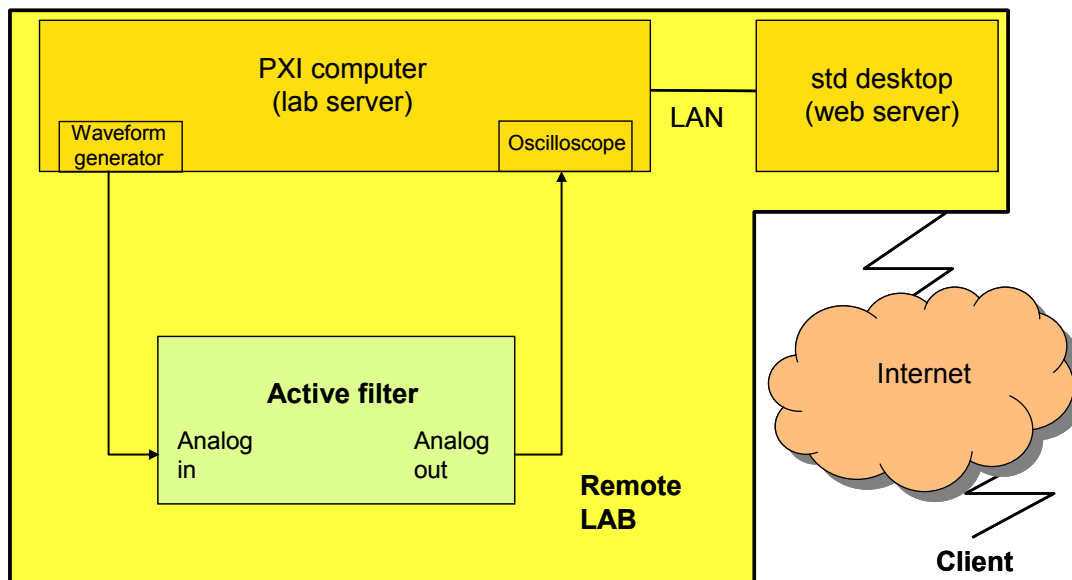

Fig. 5: Technical components underlying the remote experiments dealing with active filters.

This work assignment is presented to the students in the form of a workshop activity, as described in the previous section, and the meta-script provided includes the following information:

- An identification of the learning goal (in this case, it consists of understanding the frequency response of active filters).
- Description of the work: the students are required to design a lab script for a remote experiment meant to determine the type (low-pass, high-pass, band-pass or band-reject) and order of an unknown active filter, and to test that same script by actually carrying out the proposed steps using the active filter available in the remote workbench.
- The identification of the expected deliverables (which in this case consist of the lab script designed by the students and the report produced by carrying out the experiment proposed in this script).

- A description of the resources available in the remote workbench: in this case, the equipment available comprises a waveform generator and an oscilloscope, controllable via appropriate LabView interface panels (which were created by the instructor when designing the experiment), as illustrated in figure 6.

The students have a Flash communicator video-conferencing “room” available 24 h / day and may access the remote electronics workbench at any time. Access to the workbench must however be reserved beforehand (in one-hour slots) using the scheduling / booking application that was shown in figure 4.

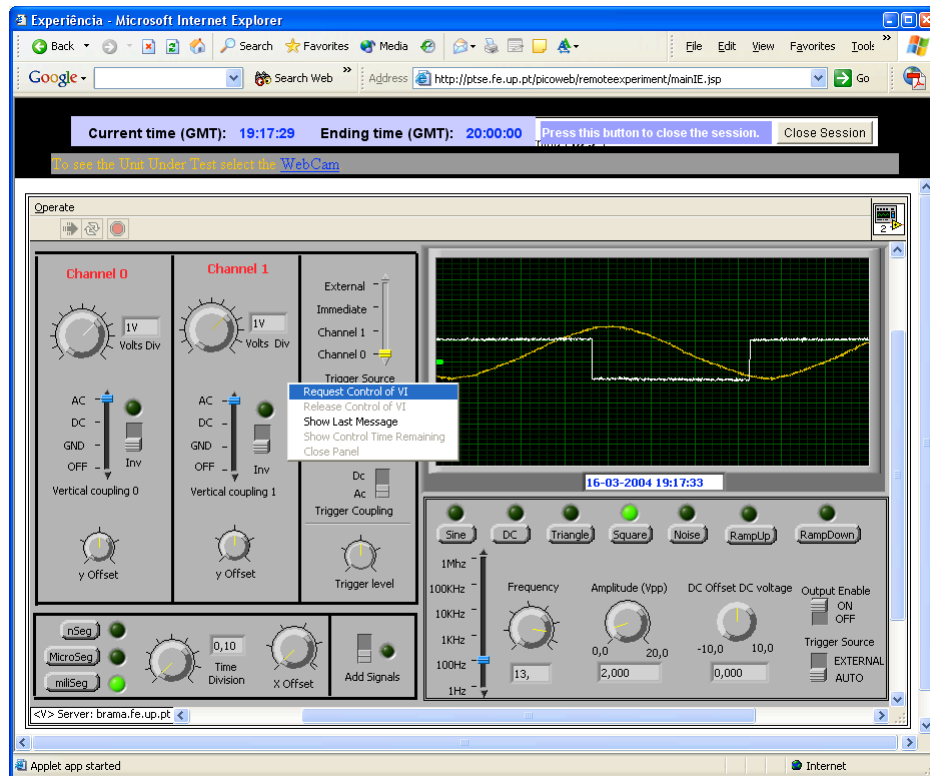

Fig. 6: The interface panels for the oscilloscope and the waveform generator.

All these resources are made available in the form of Moodle course pages, which also provide the theoretical background required to learn the basics of active filters. The tasks actually carried out by the students may be summarised as follows:

- Discuss and assess the meta-script provided by the instructor, submitting in return a document that contains a proposed workplan (with milestones and deadlines) and possible requests for further clarification
- Design a draft version of the lab script and submit it to another group for peer-review (this phase will already require usage of the remote electronics workbench)
- Make the necessary amendments and deliver the final version, including a sample report produced after carrying out the proposed script (assessment and grading of these deliverables formally closes the workshop)

Communication among the students and with the instructor occurs several times during this process and may take place either in person or remotely using synchronous or asynchronous communication tools (e.g. the video-conferencing room, email, MSN messenger, etc.).

7 Conclusion

Remote experimentation is an important complement to consolidate theoretical concepts and will find its way into the learning chain, not in replacement of simulation or on-lab experimentation, but rather as an additional tool that is available to instructors to improve the pedagogical effectiveness of their activity. There are obviously some shortcomings in remote experimentation, just as there are other types of limitations in simulation or on-lab experimentation. Just as it happens with simulation, remote experimentation is a safe way of handling complex / dangerous workbench activities, but it is not able to convey the haptic experience that may be required for the certification of professional skills. At the current state of technology, remote experimentation is a better alternative to simulation, in what concerns the time required to set up multidisciplinary experiment scenarios and closeness to reality.

The remote experimentation scenarios that are being developed within the MARVEL workplan are based on a learning model that sees workbench tasks as collaborative activities, where the students acquire knowledge by actively producing pedagogical contents. This *social constructivist* approach to remote experimentation fits well into the Moodle course management system, where the remote experiments are perceived by the students as instructional tasks that are embedded into *workshop* activities, and the collaboration with other students is required to achieve the workshop milestones. Moreover, the workshop deliverables that are required from the students are themselves pedagogical contents that are reused by other students during the peer-review phase, contributing to consolidate the underlying theoretical concepts. Each remote experiment is therefore but one component in a much wider learning setting, which encompasses the Moodle *lessons* conveying the theoretical concepts and self-assessment tools, the video-conferencing rooms required to support the collaborative activities, the remote equipment interface panels, and the accompanying management tools (e.g. the scheduling / booking application that was developed to manage access to the remote workbench equipment). Following an initial phase that developed the main conceptual model comprising the pedagogical and technological guidelines, MARVEL is now moving into a content development and delivery phase, which will provide further opportunities to evaluate the feasibility and effectiveness of the social constructivist approach that was presented in this paper. Further information about the project may be obtained by visiting the MARVEL web site at <http://www.marvel.uni-bremen.de/>.

References:

- [1] Computer Support for Collaborative Learning (Bergen Norway 2003 and Taipei Taiwan 2005), <http://www.intermedia.uib.no/cscl/welcome.cscl> (2003) and <http://www.cscl2005.org/default.htm> (2005). Computer Supported Cooperative Work (Chicago USA 2004), <http://www.acm.org/cscw2004/>.
- [2] Dieter Mueller, José M. Ferreira, "MARVEL: A mixed-reality learning environment for vocational training in mechatronics," *Proceedings of the Technology Enhanced Learning International Conference*, (TEL'03), Milan, Italy, November 2003.
- [3] Bjarne A. Foss, Kjell E. Malvig, Tor I. Eikaas, "Remote Experimentation — New Content in Distance Learning," *Proceedings of the International Conference on Engineering Education* (ICEE'01), Oslo Norway 2001.
- [4] Sven K. Esche, "Remote Experimentation — One Building Block in Online Engineering Education," *Proceedings of the ASEE / SEFI / TUB International Colloquium*, Berlin Germany 2002.
- [5] Cyberlab — The Experiment Service Provider, <http://www.cyberlab.org>.

- [6] Vivien Burr, *An Introduction to Social Constructivism*, London: Routledge, 1995.
- [7] Matt Riordan, *Moodle — An electronic classroom*, an instructor's manual to Moodle, 79 pp., <http://moodle.org/docs/teacher-manual.pdf>.
- [8] Bray J. Brockbank, "Demystifying eLearning Portals: The Convergence of Enterprise Intelligence and Learning," ITtoolbox Knowledge Management White Paper, 2001, <http://knowledgemanagement.ittoolbox.com/pub/BB011002.pdf>.
- [9] Martin Dougiamas, Peter C. Taylor, "Moodle: Using Learning Communities to Create an Open Source Course Management System", *ED-MEDIA 2003: World Conference on Educational Multimedia Hypermedia & Telecommunications*, Honolulu Hawaii USA 2003, <http://dougiamas.com/writing/edmedia2003/>.