

UC Berkeley

UC Berkeley Previously Published Works

Title

The Perils of DNA Barcoding and the Need for Integrative Taxonomy

Permalink

<https://escholarship.org/uc/item/31w9q9wv>

Journal

Systematic Biology, 54(5)

Authors

Will, Kipling

Mishler, Brent

Wheeler, Quentin

Publication Date

2005

Peer reviewed

that accompany this article, Will and Hebert respond to 10 questions selected by V.S. to reflect the balance of issues raised by the PEET audience (Hebert and Gregory, 2005; Will et al., 2005). Alternatively, you can follow the original debate as all 2 hours of the complete symposium are available to watch as a streaming video from <http://streamer.cen.uiuc.edu/seminars/peet/peet2-3-4.wmv> (Windows Media Player required).

ACKNOWLEDGEMENTS

I thank Kipling Will and Paul Hebert for taking part in the debate, Mike Irwin and Gail Kampmeier for organizing the fifth biennial PEET conference, and the National Science Foundation for financially supporting this meeting. Kevin Cummings, Martin Hauser, Andrew Miller, Mark Wetzle, and Kazunori Yoshizawa provided specimens and in some cases unpublished DNA sequences that were used during the species identification demonstration in this session. Martin Hauser, Mathys Meyer, Floyd Shockley, Daniela Takiya, and Jamie Zahniser assisted in the running of the debate. The symposium video was filmed and edited by Ritch Strom on behalf of the office of continuing education at the University of Illinois. Rasplus Jean-Yves, Kevin Johnson, Rod Page, Diana Percy, Vincent Savolainen, Jason Weckstein, and an anonymous reviewer provided comments on an earlier (and considerably different) version of this manuscript. This work was supported by a grant from the National Science Foundation (DEB-0107891).

REFERENCES

- Anonymous. 2003. What's in a name? *Economist* 366:62.
 Blaxter, M. 2003. Counting angels with DNA. *Nature* 421:122–124.
 Godfray, H. C. J., and S. Knapp. 2004. Introduction [to a theme issue 'Taxonomy for the twenty-first century']. *Phil. Trans. R. Soc. Lond. B* 359:559–569.
 Gotelli, N. J. 2004. A taxonomic wish-list for community ecology. *Phil. Trans. R. Soc. Lond. B* 359:585–597.
 Hebert, P. D. N., A. Cywinska, S. L. Ball, and J. R. deWaard. 2003. Biological identifications through DNA barcodes. *Proc. R. Soc. Lond. B* 270:313–322.

- Hebert, P. D. N., and T. R. Gregory. 2005. The promise of DNA barcoding for taxonomy. *Syst. Biol.* 54:852–859.
 Hebert, P. D. N., M. Y. Stoeckle, T. S. Zemlak, and C. M. Francis. 2004. Identification of birds through DNA barcodes. *PLoS Biol.* 2:1657–1663.
 Holmes, B. 2004. Barcode me. *New Scientist* 182:32–35.
 Kurosawa, O., and M. Washizu. 2004. Acquisition and amplification of targeted position of electrostatically stretched DNA. *J. Inst. Electrostat. Jpn.* 28:59–64.
 Lipscomb, D. L., N. Platnick, and Q. D. Wheeler. 2003. The intellectual content of taxonomy: a comment on DNA taxonomy. *TREE* 18:65–66.
 May, R. M. 2004. Tomorrow's taxonomy: Collecting new species in the field will remain the rate-limiting step. *Phil. Trans. R. Soc. Lond. B* 359:733–734.
 Moritz, C., and C. Cicero. 2004. DNA barcoding: Promise and pitfalls. *PLoS Biol.* 2:1529–1531.
 NCBI. 2005. National Center for Biological Information. GenBank statistics available at <http://www.ncbi.nlm.nih.gov/About/tools/restable.stat.html>.
 Nicholls, H. 2003. DNA: The barcode of life? Originally published on behalf of Elsevier by BioMedNet. Now available at <http://www.uoguelph.ca/~phebert/media/BioMedNet%20News%20article.pdf>.
 Pennisi, E. 2003. Modernizing the tree of life. *Science* 300:1692–1697.
 Rodman, J. E., and J. H. Cody. 2003. The taxonomic impediment overcome: NSF's Partnerships for Enhancing Expertise in Taxonomy (PEET) as a model. *Syst. Biol.* 52:428–435.
 Schindel, D. E., and S. E. Miller. 2005. DNA barcoding a useful tool for taxonomists. *Nature* 435:17.
 Tautz, D., P. Arctander, A. Minelli, R. H. Thomas, and A. P. Vogler. 2003. A plea for DNA taxonomy. *TREE* 18:70–74.
 Taylor, R. W. 1983. Descriptive taxonomy: Past, present, and future. Pages 93–134 in *Australian systematic entomology: A bicentenary perspective* (E. Highley, and R. W. Taylor, eds.). CSIRO, Canberra.
 Vincent, M., Y. Xu, and H. Kong. 2004. Helicase-dependent isothermal DNA amplification. *EMBO Rep.* 5:795–800.
 Will, K. W., B. D. Mishler, and Q. D. Wheeler. 2005. The perils of DNA barcoding and the need for integrative taxonomy. *Syst. Biol.* 54:844–851.

First submitted 23 March 2005; reviews returned 9 June 2005;
 final acceptance 12 July 2005
 Associate Editor: Vincent Savolainen

Syst. Biol. 54(5):844–851, 2005
 Copyright © Society of Systematic Biologists
 ISSN: 1063-5157 print / 1076-836X online
 DOI: 10.1080/10635150500354878

The Perils of DNA Barcoding and the Need for Integrative Taxonomy

KIPLING W. WILL,¹ BRENT D. MISHLER,² AND QUENTIN D. WHEELER³

¹ESPM Department—Insect Biology and ²Department of Integrative Biology, University of California, Berkeley, California 94720, USA
³Natural History Museum, Cromwell Road, London, SW7 5BD, UK

"Your work, Sir, is both new and good, but what's new is not good and what's good is not new."

Samuel Johnson

We argue that DNA barcoding has both new and good elements, but unfortunately no elements that are both. We are strongly in favor of the good idea of using DNA for identification, but that is old hat—the use of DNA for identification goes back to the beginning of molecular

systematics. The DNA barcoders cannot take any credit for that. Their new idea that DNA barcoding can replace normal taxonomy for naming new species and studying their relationships is worse than bad, it is destructive. Statements by some barcoding proponents suggest an inevitable replacement of taxonomic research rather than augmentation of technology to taxonomic science, e.g., "a COI-based identification system will undoubtedly

provide taxonomic resolution that exceeds that which can be achieved through morphological studies. Moreover, the generation of *cox1* (= COI) profiles will provide a partial solution to the problem of the thinning ranks of morphological taxonomists by enabling a crystallization of their knowledge before they leave the field." (Hebert et al., 2003a:319) and "If taxonomists fail to embrace molecular technology, Hebert is clear about the consequences: "There is no more likely death of a discipline than the failure to innovate.'" (P. Hebert as quoted by Nicholls [2003]).

Rather than such a gloomy and narrow prospect for taxonomy we promote using all available resources to build real capacity to do the job right. An overemphasis on the barcoding approach could easily distract taxonomy from its scientific goals and siphon off resources for systematics just at the time it is poised to blossom, thanks to all the integrative programs underway at the U.S. National Science Foundation (NSF) and elsewhere. Contrary to their posturing as cutting-edge, by emphasizing a single gene as a "universal barcode" (Powers, 2004:371), DNA barcoders are returning to an ancient, typological, single-character-system approach. Note that we are not defending "traditional taxonomy" here, but instead we argue that the real cutting-edge future for systematics and biodiversity research is *integrative taxonomy*, which uses a large number of characters including DNA and many other types of data, to delimit, discover, and identify meaningful, natural species and taxa at all levels.

The following text is in direct response to 10 questions selected from issues raised during a DNA barcoding debate between K. Will and P. Hebert held at as part of the fifth PEET conference at the University of Illinois in Champaign-Urbana (20–23 September, 2004). Further details can be found in the adjoining articles in this issue (Smith, 2005; Hebert and Gregory, 2005). Our article is intended to be balanced by responses written by P. Hebert to the same questions. The tone and content of this submission reflects the ad hominem nature of the debate, limitations set by the questions themselves, and context at the time of the debate. Though some aspects of this article may seem to some as "dated" by the time they reach publication, we believe that most of the serious issues remain.

SUBMITTED QUESTIONS AND OUR ANSWERS

1. *Given two billion US dollars (the amount a comprehensive program of DNA barcoding is estimated to cost [Whitfield, 2003]), how would you spend this money to benefit taxonomic and biodiversity research, and what would be the legacy of these data?*

We would use it for education and capacity building, with a true vision for the future! Very simply, the well-worn analogy of the boy and the fish applies here—Give a boy a fish, he eats for a day. Teach a boy to fish and he eats for life. Clearly we have the potential to gain massively if we are willing to invest in the value option of taxonomy and the development of a complex understanding of the

natural world. The basic understanding of what species and higher-taxa are is fundamental to biology and still so controversial that it would be both arrogant and foolish to fail to invest in the human resources necessary to discover, enumerate, and, most importantly, understand biodiversity.

Because of the long history of taxonomy in many Holarctic countries, the major effort and richest taxonomic work, coupled with a broad array of life history data, has been done by taxonomists living within these countries and on their fauna. The most important regions of biodiversity and our worst ignorance of that diversity are in other parts of the world. The greatest long-term impact of this imagined money would come from establishing training opportunities and positions for researchers and students in the parts of the world with the greatest biodiversity to discover. Each of us knows mentors that have produced a cadre of students who collectively have had a tremendous impact on taxonomy, systematics, and biology. Establishment of programs based on models like PEET (www.nhm.ku.edu/peet/), LINNE (Page et al., 2005) (www.flmnh.ufl.edu/linne/default.htm), and ATOL (www.nsf.gov) throughout the world, and support of taxonomic research positions in universities and museums would have a propagating effect into the future of biological research.

The on-going NSF sponsored workshops for LINNE (Legacy Infrastructure Network for Natural Environments) offers a visionary cyber-infrastructure for collections-based "descriptive" taxonomy that would diminish or eliminate many of the obstacles to rapid growth of taxonomic knowledge. Such an approach is driven by taxonomy as a science and would rapidly generate the kind of sound knowledge needed to understand the diversity of life at and above the species level. That research lays the appropriately scientific foundation upon which DNA identification tools should be built. \$US 2 billion would easily fund LINNE and a veritable army of taxonomists who could discover and describe species, expand natural history museums and herbaria to reflect the living world, and elucidate the fascinating patterns of biology worthy of our detailed future study. None of these benefits accrue from a massive barcoding exercise. Capitalizing on theoretical advances in systematics in combination with cyber-infrastructure is a far superior approach and one that paves the way for truly useful DNA and morphological markers to identify species.

With two billion dollars neither DNA barcoding nor a robustly funded effort to address biodiversity using an integrative approach would achieve 100% success by any reasonable measure. The question then is what is gained for the investment. Undoubtedly more "items," in a typological sense, might be enumerated by focusing on a small piece of DNA, but this would necessarily leave details of what is meaningful aside. However, even if fewer items are enumerated per dollar by an integrative approach, these will be evolutionarily significant units, and the ultimate product is scientific with far reaching impacts.

2. *Globally, alpha taxonomic research (the discovery and description of new species) is in crisis. Is DNA barcoding an expedient solution to this problem or will it expedite its decline?*

DNA barcoding is neither a solution, stop-gap, replacement nor a surrogate for doing systematic science. Regardless of the character system, alpha taxonomy should not be practiced in an intellectual vacuum. Description of taxa based on any single-character system, whether solely morphological or a single gene, will be deficient without an appropriate context. However, unlike DNA barcoding, which is a back-slide into phenetics and typology, even a modest morphological description immediately provides possible connections to life history, behavior, and taxonomic status. At best, DNA barcoding, without underlying integrative taxonomy, provides only some level of phenetic difference for a small piece of DNA that might correspond to named taxa at an arbitrary cut-off (potentially with an unacceptably high error rate).

Initiation of a global scale DNA barcoding effort would create a necessary early demand for alpha taxonomic work as a service to the barcoding industry. There would also be an initial demand from genuine taxonomists requesting barcoding services for revised groups they wish to test or develop identification tools. Ultimately, easy groups and groups with current interest (economic or scientific) would be completed and yet many millions of samples for nameless and undescribed items that may or may not be valid taxa would remain.

Unlike the Human Genome project (www.genome.gov), with its ready body of users and funding waiting to act on the immediate product, DNA barcoding lacks an actual or potential wave of taxonomists and any vision for sufficient funding to match the magnitude of these data. However, there are many biologists outside of systematics that feel their studies are stymied without taxonomic revisions. These ecologists, behaviorists, conservation biologists, etc., will, without a doubt, move ahead with items identified by DNA barcoding. They will accept the level of noncorrespondence of these units to taxa and instead of taxa will use so-called “gene-species” or “molecular operational taxonomic units” (MOTUs) (Blaxer, 2004), generating a false sense of security that nature has been successfully described. This will be similar to the confusion generated when “morphospecies” have been used as surrogates in ecological and biodiversity studies. However, because of an unjustified and poorly articulated trust in DNA characters over other character systems, and the apparent ease of barcoding methods, gene-species have the potential to be much more pervasive and damaging to integrative taxonomy, including the alpha level step.

3. *Overlapping character variation between and within species is well documented for many character systems. Why is this any more or less of a problem for DNA barcoding?*

This isn't a particular problem for DNA barcoding; it is truly a problem for all character systems. The difference is that integrative taxonomy is able to overcome overlapping character variation in a particular character system

by bringing to bear evidence from many other character systems. DNA barcoding is stuck with its single, simple character set. DNA barcoding has no way to overcome this common phenomenon—unless of course it brings in other genes and morphological characters and becomes integrative taxonomy! This change indeed has been suggested by recent, moderate supporters of barcoding (e.g., Schander and Willassen, 2005; D. Schindel, Consortium for the Barcode of Life [CBOL], personal communication), but then the question becomes: why continue to promote a universal barcode and “DNA profiles” (Hebert et al., 2003a) for species if in fact the intent is to refer to a multicharacter integrative approach? Despite some lip-service to moderation, the most obvious promotion is still the one-gene approach to identification. For example: “The method that will enable this advance is ‘DNA barcoding,’ an approach that employs a small fragment of DNA, a portion of a single gene, to provide a unique identifier—a ‘DNA barcode’—for each living species on Earth” and “This website describes work related to the creation of a DNA-based identification system for animals-at-large based on the analysis of a single mitochondrial gene—cytochrome oxidase subunit I (*cox1* = COI)” (www.barcodinglife.org).

Even a single morphological character in most cases is likely a summary of many genes and thousands of base pairs, filtered by eons of natural selection and canalized by the hierarchy that results from a history of common ancestry. Such a rich, highly predictive, broadly explanatory understanding of species, as given by evolutionary history, offer an imminently more interesting and powerful approach to taxonomy than the comparatively easy but relatively uninformative and phenetic barcoding alternative.

Only through the ignorance of arrogance could one fail to learn the lessons of several centuries of comparative morphology. Single-character systems rarely work for even one truly diverse clade and never work for all clades. It is this remarkable diversification of life that makes taxonomy, natural history, and phylogenetics subjects of enduring interest. There is no need for a thinking community to expend great sums of money to reinvent this wheel: different, multiple genes will be needed to have reliable identifications of different clades and these should be developed logically in the context of a credible existing taxonomy.

4. *Many taxonomists already practice DNA barcoding informally when delimiting and discovering species. Is this wrong, and what data is sufficient to demonstrate that a series of specimens represents a new species with traditional or barcoding methods?*

In many cases the term DNA barcoding is being applied as a neologism captured but not coined by marketing-savvy biologists for well-established methods of investigating species-level boundaries (Hebert et al., 2004). The means used by modern taxonomists to delimit and discover species and the tools provided for identification does include the use of DNA data. However, this is best done in the right order and measure. The

idea that has been promoted that DNA barcoding should be the first and principal step in delimiting and discovering biologically important units in nature is fraught with problems. Chief among these is the mistaken idea that differences in a single-character system will identify species across all or nearly all life. Such a notion is a throw back to ancient typological thinking that over the last few hundred years has been shown repeatedly to be faulty. This, coupled with the phenetic view of currently implemented DNA barcoding methods, makes using DNA barcoding as a primary step a costly attempt to preserve the worst aspects of traditional taxonomy! Integrative taxonomy, however, can and does use DNA data, and all types of data, to delimit, discover and identify meaningful, natural species and taxa at all levels. Thus the debate over barcoding is *not* DNA versus morphology, but rather single-character system, e.g., single gene, systematics versus integrative, multiple-character systematics.

All methods of species "discovery" depend heavily on the underlying species concept of the investigator and the data available to him or her. Even among the three of us there is little consensus as to the best species concept, or even the importance of species as a taxonomic rank, a situation that mirrors the broader biological community (Wheeler and Meier 2000; Wilson 1999). What we are unified on is that DNA barcoding methods, as presently devised as a first or only step, are very likely to fail to recover phylogenetically and biologically meaningful units and will mask error by presenting an artificially simple view of the world, dressed in ostensibly innovative technology. Its deficiencies are apparent to anyone practicing integrative taxonomy.

5. *The proposed barcoding genes can fail to recover accurate species trees. Does this matter for DNA barcoding?*

Despite obvious failure in the early works on DNA barcoding, the "correct" identification of a specimen to its higher-level taxon was proposed as one of the major selling points (Hebert et al., 2003a:318, 2003b:S98). However, Hebert in this debate now tells us that DNA barcoding is only intended to address the leaves of the tree. This moving target approach is not surprising and perhaps even commendable if it in fact represents a response to criticism and obvious methodological failings.

However, this still presumes that the higher-level taxonomy is done, or no name will be available for a sequence semaphorant. It also presumes that species are not themselves a phylogenetic hypothesis, a highly debatable position at best.

Attempts to avoid the problems of higher taxa also ignore the fact that mtDNA characters are hierarchically arranged when using neighbor-joining or other tree-building methods. There is no reason to assume that we can identify what a species-level group of individuals versus a separate genus is with DNA barcoding without a preexisting taxonomy and systematic revision. An arbitrary percent-difference cutoff could be applied, but

this not justifiable given our understanding of evolution. Shifting away from applying barcodes to higher taxa does not save this program. Methodologically, barcoding results in a hierarchy down to the individual sequence semaphorant level and therefore does not allow for a nonarbitrary, uniform means of taxon recognition without an existing taxonomy and a broad sampling of haplotypes.

6. *Some species are not mitochondrially monophyletic, sharing polymorphisms with unrelated taxa. How will this affect identifications using a barcoding approach?*

The problem lies with species concepts and methods of species recognition. If your species concept is primarily reliant on interbreeding and production of viable offspring and such data are available (i.e., the biological species concept; Mayr, 2000), paraphyly of one-character system is meaningless. If you maintain one of the many other species concepts (e.g., various forms of the "phylogenetic" or "evolutionary" species concepts (Wheeler and Meier, 2000; Wilson, 1999), the current DNA barcoding approach does not give you the information you need to decide whether a cluster, grade, or leaf is a species or not.

Many possible complications may arise given various haplotypes and shared ancestral polymorphisms in mtDNA. Even simple paraphyletic gene-trees are problematic (Funk and Omland, 2003). Given a described sister pair of species each known to be composed of interbreeding individuals and samples of individuals from *Species 1* = A,B,C; *Species 2* = D,E,F and an unidentified fragment that has been sequenced = X, one possible resulting NJ gene-tree is (D(E(F(X(A(B,C)))))) (Fig. 1). In such a case the new sequence cannot provide an unambiguous identification. In this case X may be a member of *Species 1*, as it is sister to (A(B,C)) but could also be identified as *Species 2* as it lies within the convex group

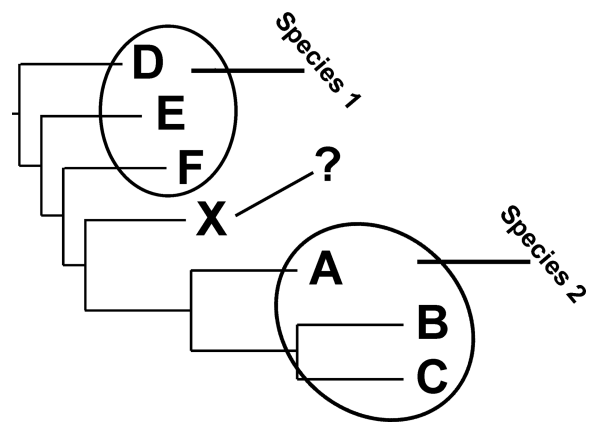

FIGURE 1. Diagram showing potential problem of determining a species identification using the barcode protocol. The unknown sequence semaphorant is X, sequence semaphorants sampled from an interbreeding population considered to be Species 1 are D, E, and F, and similarly A, B, and C are from Species 2. The individual represented by X could be placed in Species 2 or with Species 1.

(Estabrook, 1986) D,E,F (Fig. 1). DNA barcoding alone is helpless to resolve this.

If sampling is restricted to few individuals and species are likely to have a relatively ancient split from a common ancestor, and/or are the result of allopatric speciation, then one may expect constant and relatively large differences between species-level taxa. Published barcode studies have used these types of samples (e.g., Hebert et al., 2004; Hogg and Hebert, 2004). Very recent, close sister taxa and highly variable populations are yet to be sampled. Current sparse and selective samples probably indicate that the purported accuracy of the method is about as good as it will get. Denser samples can only increase the likelihood of failure as the amount of variation can only increase.

7. *Should the completion of a DNA barcoding program ever occur, would this mark the beginning or end of taxonomic and biodiversity research, and what will be the role of systematists in a world where most identifications are done by "barcode"?*

If a DNA barcoding system was "completed," in any sense of the word, then this would have to be something very different than what is currently envisioned. It would require sets of different, suitable genes selected for different groups of plants, animals, and bacteria. If this is what people are aiming to do, then this is integrative taxonomy and the proposed economy of DNA barcoding is marginalized. As such, this would certainly be useful for identification purposes, especially in difficult cases where key morphological characters are missing. However, as we point out above (Question 3), there does not seem to be an ostensible consensus in the barcoding community to pursue integrative taxonomy.

Regardless, the role of systematists would continue to be what it is now, to discover and characterize taxa using all available data. Identification is one thing, a service that systematics supplies to its users, but discovery and delimiting taxa are very different. They are the core of the science of systematics, and barcoding cannot replace that.

There exists an underlying confusion between identification and classification. Although taxonomy is not experimental, it is unequivocally scientific. As such, taxonomy is never finished. Hypotheses about species and monophyly must be retested with discoveries of new characters, populations, or species. Barcodes for species hypotheses would have to be tested too and in some cases recalibrated to remain an accurate reflection of the best species hypotheses. That the DNA barcoding library could be completed as currently conceived reveals its stark contrast as a non-science to the science of taxonomy.

8. *Would the inevitable expansion of sequencing efforts that would come with a program of DNA barcoding be concomitant with a decline in the quality of taxonomic research?*

There is confusion of DNA barcoding with molecular systematics in general. The use of DNA in systematics

is an established tool. Expansion of sequencing efforts can only increase the quality of integrative taxonomic research. All current graduate student projects in systematics we know of, and we expect the large majority worldwide, are based on a rich mix of sequencing of a number of unlinked genes, along with morphological, ecological, and biogeographic studies, that rigorously test phylogenetic hypotheses of relationships. To return to an Aristotelian single-character approach is misguided in the extreme—it flies in the face of all the progress made during the development of phylogenetic systematics. DNA barcoding as a first and primary step, is against what we teach as good science in such quality programs as PEET.

9. *Assuming the technical problems of DNA barcoding can be overcome, is it now, or will it ever be, cost-effective relative to traditional methods to use DNA barcodes for bioinventory purposes?*

If the technical and methodological problems of DNA barcoding were overcome, then it would cease to be DNA barcoding as it is presently proposed. The only certain way to overcome the inherent problems is to do integrative taxonomy first. Once a solid taxonomy is established the most useful character data, be that *cox1*, other sequences, or morphology, can provide a means for identification.

If the intention is to use mtDNA alone to generate bioinventory data, then these data will be deficient and suffer from the numerous shortcomings that we have outlined above. We would be astonished if any credible scientists would accept the diversity of *cox1* haplotypes sampled from an area as a valid or meaningful measure of biodiversity. Certainly agencies receiving reports from the biological community on which they will base conservation and land use decisions should demand more rigorous and established methods before making such important choices. However, it is possible that ignorance of the method and momentum of the hype could result in rash and irreversible mistakes that will impact significant elements of biodiversity.

10. *Hypothesis-driven research is the foundation upon which most research agencies assign funding priorities, yet taxonomy is discovery driven. How would your approach to taxonomy convince these agencies of the merits of taxonomic studies?*

Taxonomy need be no more discovery driven than chemistry or physics. Hypotheses are generated in all these fields by discovering interesting patterns in nature; they are then tested using appropriate rules of inference. It is true that taxonomy was once largely discovery driven, though good taxonomy has always been and remains based on hypotheses. Historically some taxa lacked sufficient scientific rigor; that, and a general misunderstanding of the scientific nature of taxonomy, nearly killed the field. But modern systematics is as meticulous and hypothesis-based as any science. In modern phylogenetic systematics, hypotheses of relationships are tested by adding new character systems one

after another, using rigorous rules of inference. Oddly enough, rather than leading us forward in modern integrative taxonomy, the proponents of DNA-barcoding seem to be leading the field back to a “descriptive” age of systematics. In a more integrative approach a species level hypothesis is presented in the form of a well-written description, but even bad species descriptions are testable. In fact these can be rather quickly rejected and synonymized. Good ones hold up very well to hundreds of critical tests. A monograph or revision once or twice per century, however, does not provide the frequency of hypothesis testing necessary to keep those hypotheses relevant in light of all known species, populations, and characters. In the age of cyber-infrastructure, digital tools, and IT, most of the weights that have held taxonomy back are gone. Now that we have the tools to vastly accelerate good taxonomy, it is in danger of being tossed out like rubbish for the latest parlor trick.

One reason taxonomists are not more broadly funded to simply or primarily describe taxa is in part because we now recognize that doing “traditional taxonomy,” in the inaccurate caricatured sense in which it is so often portrayed, provides a deficient product. Our expectation is that taxonomy will provide not just the most expedient product, but a high-quality product. Our view is not that we are preserving traditional taxonomy, rather we envision the future of taxonomy as descriptive and hypothesis based. DNA barcoding as a first and primary step preserves only the worst aspects of “traditional taxonomy” in being both typological and phenetic. Governmental funding agencies will and have recognized its defective nature and we are certain that any proposal that has a disproportional and/or ill conceived use of “barcoding” will correctly fail to receive funding.

There has been a slow but growing realization in funding agencies that a strong integrative taxonomic base, with broad and deep phylogenetic studies and the coupling of intellectual merit and broader impacts to taxonomic studies, benefits all of biology. As the biological community realizes that taxonomy is providing a useful and high-quality product that is a mix of discovery and hypothesis driven research, funding will continue to grow. If there is an illusion that the job has been completed because everything has been “barcoded” or when users of taxonomic products find taxonomists are no longer conducting science, funding opportunities will be lost.

POSITION STATEMENT

“The noisome weeds which without profit suck
The soil’s fertility from wholesome flowers.”

William Shakespeare, *The Tragedy of King Richard II*

Much of what the barcoding proponents are saying seems to have new ring to it but, for the most part, it is not new at all. The use of a so-called DNA barcode for identification (Hebert et al., 2003a, 2003b) is recognized as nothing fundamentally new (Moritz and Cicero, 2004; Sperling, 2003). Even the term “DNA barcode” it-

self was introduced 10 years prior to its latest manifestation (Arnot et al., 1993). The use of a minimal set of characters to allow relatively fast identification of taxon membership is not new; it is in fact coextensive with taxonomy itself. The storage, retrieval, and transmission of information are fundamental to classification, and if a taxon name has meaning at all, we must also provide a means to transmit that information. This idea is of course nothing new, it is what systematists do.

The use of sequence or genetic data as part of this identification process (as one possible character set) is also not new; over the past 15 years we have seen various methods applied, e.g., rDNA and mtDNA analyses, allozyme analysis, competitive PCR, and DNA hybridization, just to name a few. The appropriate use of these data and methods has proven that there are both uses and limitations of this character system. The idea of gathering and using a standard set of genes for all taxa is not new or unique to the recent DNA barcoding movement (Caterino et al., 2000; Sperling, 2003).

Blind, preemptive sequence harvesting, or establishment of “gene-species” as a primary step in taxonomy, does represent a fundamentally new and disturbing emphasis. However, critical assessment by any practicing taxonomists quickly leads to a realization that what might be considered good in DNA barcoding is not new, and what is new is not good.

The extreme form of barcoding envisions replacing the “messy” science of taxonomy with something objective, easy, and quick—something nonscientific. This barcoding hardline is a slap in the face to quality taxonomic studies and diverts our focus and energy away from the real objectives of taxonomy and systematics. Barcoding ultimately cannot answer the hard questions of taxonomy; instead it provides little more than a funding will of the wisp and a path leading from DNA-based identification into the swamp of DNA-based taxonomy (Tautz et al., 2002, 2003).

It is important to make a clear distinction between DNA taxonomy, which is scientific, but arguably based on bad science (Tautz et al., 2002, 2003; Seberg et al., 2003; Lipscomb et al., 2003) and DNA-based identification, which may be useful as *applied taxonomy* if done properly, but bad if done alone or primarily. DNA taxonomy is an initiative to replace the current multicharacter integrative approach to taxonomy with a focus on a small portion of the genome, whereas DNA identification as practiced by the barcoders is intended to provide names for sequence semaphorants. One might argue that the two are fully decoupled. In the absence of robust programs in taxonomic research, however, it is certain that DNA taxonomy will follow closely on the heels of any large scale DNA-barcoding effort. In our current academic climate of “publish or perish,” biologists will naturally rationalize the use of “gene-species” or MOTUs (Blaxter, 2004) identified by clustering barcode sequences. This would appear to provide a fast and convenient surrogate for taxa. However, Hebert in this debate and other barcode proponents have admitted that we will need taxonomic expertise to assign names to items found

by barcode analyses. But this is relegated to subsequent clean-up—In an article in the now defunct online journal *BioMedNet News*, Harvey Nicholls writes that “Hebert envisages this ‘gene species’ as a first, mandatory step towards describing a real species. At a later stage, traditional taxonomists could make the formal morphological description of the specimen, which would then become associated with its DNA barcode, he suggests.” (This article is available as an appendix on the *Systematic Biology* website, www.systematicbiology.org.)

The essence of the envisioned large-scale DNA barcoding proposal rests on the idea that once effort and money has been diverted to building a worldwide *cox1* database, “traditional taxonomists” will service this vast, but largely scientifically barren assemblage of data, which has been harvested from a single character system. Far more likely is the scenario that it will be used “as is” by most of biology. The chronically underfunded field of taxonomy will be further marginalized by the diversion of attention and funds. This will exacerbate the situation by failing to promote the training of new taxonomists and will diminish any prospect in the field by reducing it to providing “the formal morphological description of the specimen, which would then become associated with its DNA barcode.” (P. Hebert, quoted in Nicholls, 2003). Such an enterprise would not be remotely interesting to anyone. What to some seems a temporary expediency will lead us to reflexive belief. Emphasis and dependence on DNA barcoding will inevitably lead to typological and phenetic DNA taxonomy.

At its best, DNA barcoding includes the well-known use of sequence data to help as a heuristic estimate of relative differences between populations and potentially distinct species. Through sequence identity it may also provide association of partial specimens and various life history stages, typically, with their adult forms and taxon names. The production of a system of vouchering and databasing standard sequences, a potentially useful tool for many biologists, is also commendable (but of course not new). This system will only be useful if the taxonomy of a group is already well developed. Taxonomy has become an increasingly rigorous science over the past 50 years with “descriptive” alpha taxonomy driven by critical species hypothesis testing, predictive phylogenetic classifications, and increasingly informative Linnaean names. Taxonomic research, broadly comparative and historical, is a necessary intellectual counterbalance to general experimental biology. DNA barcoding is most appropriately seen as applied taxonomy, that is, as a potentially important and powerful tool to assist in species identification. However, its utility is yet to be properly tested in the primary literature and methods remain primitive and unsound (Will and Rubinoff, 2004). The gathering of this small part of the genome adds little to the pressing need to explore, discover and describe species; the urgent need to document morphological and natural history patterns requiring a phylogenetic explanation; or the scientific process of classification. Most of the recent, exciting theoretical and practical advances in taxonomy are ignored or undermined by a strictly

DNA barcode approach that replaces deep, testable theories with arbitrary phenetic estimates of species diversity (Lipscomb et al., 2003).

Barcoding proponents have denigrated taxonomy and systematics by juxtaposing a straw-man “traditional taxonomy” and DNA barcoding in attempts to promote their priorities. For example, Marshall (2005), in his article titled “Will DNA Bar Codes Breathe Life into Classification?,” states that “Biologists hope that a simple tag on all forms of life, and even a hand-held reader, will make classification a 21st century science.” Others have the disparaged the products of taxonomy, referring to them as insufficient “collaterals” (Janzen, 2004) and presented the field as unresponsive to technology (P. Hebert as quoted by Nicholls, 2003). At the same time there has been a gross overstatement of the utility of mtDNA or, at least, a complacency toward well-known problems with organellar DNA for this purpose (Funk and Omland, 2003; Thalmann et al., 2003; Tautz et al., 2003). Such imbalanced treatment cannot be considered good science.

Barcoding has not been promoted in a scholarly manner. At the time of writing this article, primary literature papers, outside of the initial two papers introducing current barcoding methods (Hebert et al., 2003a, 2003b), that actually use barcoding methods, number only about seven (www.barcodinglife.org). However, at the same time popular media articles and promotional papers on the topic number nearly 50 (www.barcodinglife.org). Sperling (2003) was correct when he stated that “astute media management skills” were at play. We find it less disturbing that the core proponents of barcoding, e.g., P. Hebert, might so promote their ideas vigorously, and more distressing that numerous individuals and institutions (listed at www.barcodinglife.com) apparently need no higher attribute than its perceived money-garnering abilities to support barcoding. The paucity of actual tests of the methods in the literature and a community cognizant of the likely limitations of such a strategy suggests either a willingness to adopt this cause unconditionally or cynically for short term gain. Neither approach is appropriately scholarly.

A primarily DNA barcoding-driven taxonomy is costly by more than by monetary measures. There is also the human cost, if training and hiring of integrative taxonomists lags. Because of the complexity and historical contingency of nature we have, from the beginning of any study, a need to draw on a variety of data types to produce a meaningful product. Recent improvements in automated methods for gathering morphological and molecular data, as well in informatic tools for integrating data and specimens across studies, have led to greater efficiencies in taxonomy. However, it is more difficult to gain in economy of scale for many aspects of taxonomic work. To thoroughly treat a large group is hard and only moderate gains are realized over revising many small groups. DNA barcoding’s apparent gains are only made by circumventing necessary tasks and by the production of a deficient product. Much data may be collected but what is lost is the greater understanding of what those data mean or don’t mean. Though hailed as

a curative for over burdened and undermanned taxonomic research, barcoding actually adds an extra step; claims of discovery and actual discovery are decoupled. Much more will be lost if more institutions and individuals feel compelled to shortcut their research to satisfy the current vogue. If the academic and governmental bureaucracies sense a flow of dollars to a wide-scale preemptive barcoding initiative now, and ultimately see a declaration of unconditional success (as is always the case when large amounts of money have been spent), they will perceive that taxonomy is complete. At that point we can envision little motivation for universities to develop new positions for taxonomists. Paul Hebert in this debate stated that 80% of the barcoding proposed budgets will go to museum support to handle voucher specimens, store template DNA, and related activities. We will watch expectantly to see who the beneficiaries of future funding are and be hopeful for a follow-through on this statement.

In the end a broad-scale DNA barcoding effort will result in a highly deficient product that is not a replacement for real taxonomy (i.e., the result will be at best a telephone book of life as opposed to an encyclopedia of life). It is not a serious alternative to good taxonomy as it is now practiced. In an imagined future world where fundamental taxonomy has largely been completed through integrative methods, DNA identification could provide cost-effective tools for some known species and a hint as to additional species level units, but it is not a serious approach to species discovery, hypothesis-testing, phylogeny, or classification. We are now at a pivotal position in the history of the field where our tools and understanding are developed to a point that we can expand initiatives that will be a solid foundation for biology. Now is the time to invest in the fertile option of integrative taxonomy, not the noisome weed of DNA barcoding.

NOTE

Concurrent with the submission of our final manuscript of this article, but unknown to us at that time, B. Dayrat published a paper, coining and defining the term "Integrative taxonomy" (2005; Towards integrative taxonomy. *Biological Journal of the Linnean Society*. 85:407–415). Our use of the term is consistent with his, although we would differ in details of its implementation.

REFERENCES

- Arnot, D. E., C. Roper, and R. A. Bayoumi. 1993. Digital codes from hypervariable tandemly repeated DNA sequences in the *Plasmodium falciparum* circumsporozoite gene can genetically barcode isolates. *Mol. Biochem. Parasitol.* 61:15–24.
- Blaxter, M. L. 2004. The promise of a DNA taxonomy. *Phil. Trans. R. Soc. Lond. B* 359:669–679.
- Caterino, M. S., S. Cho, and F. Sperling. 2000. The current state of insect molecular systematics: A thriving Tower of Babel. *Annu. Rev. Entomol.* 45:1–54.
- Estabrook, G. F. 1986. Evolutionary classification using convex phenetics. *Syst. Zool.* 35:560–570.
- Funk, D. J., and K. E. Omland. 2003. Species-level paraphyly and polyphyly: Frequency, causes, and consequences, with insights from animal mitochondrial DNA. *Annu. Rev. Ecol. Syst.* 34:397–423.
- Hebert, P. D. N., A. Cywinska, S. L. Ball, and J. R. deWaard. 2003a. Biological identifications through DNA barcodes. *Proc. R. Soc. Lond. B: Biol. Sci.* 270:313–321.
- Hebert, P. D. N., and T. R. Gregory. 2005. The promise of DNA barcoding for taxonomy. *Syst. Biol.* this issue.
- Hebert, P. D. N., E. H. Penton, J. M. Burns, D. H. Janzen, and W. Hallwachs. 2004. Ten species in one: DNA barcoding reveals cryptic species in the neotropical skipper butterfly *Astrartes fulgerator*. *Proc. Natl. Acad. Sci. USA* 101:14812–14817.
- Hebert, P. D. N., S. Ratnasingham, and J. R. deWaard. 2003b. Barcoding animal life: Cytochrome c oxidase subunit 1 divergences among closely related species. *Proc. R. Soc. Lond. B Biol. Sci. (Suppl.)* 270:S96–S99.
- Hogg, I. D., and P. D. N. Hebert. 2004. Biological identification of spring-tails (Hexapoda: Collembola) from the Canadian Arctic, using mitochondrial DNA barcodes. *Can. J. Zool.* 82(5):749–754.
- Janzen, D. 2004. Now is the time. *Phil. Trans. R. Soc. Lond. B* 359:731–732.
- Lipscomb, D., N. Platnick, and Q. Wheeler. 2003. The intellectual content of taxonomy: A comment on DNA taxonomy. *Trends Ecol. Evol.* 18:64–66.
- Marshall, E. 2005. Will DNA bar codes breathe life into classification? *Science* 307:1037.
- Mayr 2000. The biological species concept. Pages 17–29 in *Species concepts and phylogenetic theory: A debate* (Q. D. Wheeler, and R. Meier, eds.). Columbia University Press, New York.
- Moritz, C., and C. Cicero. 2004. DNA barcoding: Promise and pitfalls. *PLoS Biol.* 2:e354.
- Nicholls, H. 2003. DNA the barcode of life? *BioMedNet News*. (Available at <http://systematicbiology.org>, Courtesy of Elsevier 2004.)
- Page, L. M., R. Beaman, F. Funk, M. Jeffords, D. Lipscomb, M. Mares, S. Noble, A. Prather, D. Stevenson, J. Stevenson, and Q. Wheeler. 2005. LINNE: Legacy Infrastructure Network for Natural Environments. Illinois Natural History Survey, Champaign, Illinois.
- Powers, T. 2004. Nematode molecular diagnostics: From bands to barcodes. *Annu. Rev. Phytopathol.* 42:367–383.
- Schander, C., and E. Willassen. 2005. What can biological barcoding do for marine biology? *Mar. Biol. Res.* 1:79–83.
- Seberg, O., C. J. Humphries, S. Knapp, D. W. Stevenson, G. Petersen, N. Scharff, and N. M. Andersen. 2003. Shortcuts in systematics? A commentary on DNA-based taxonomy. *Trends Ecol. Evol.* 18:63–65.
- Smith, V. S. 2005. DNA barcoding: Perspectives from a "Partnerships for Enhancing Expertise in Taxonomy" (PEET) debate. *Syst. Biol.* 54:841–844.
- Sperling, F. 2003. DNA Barcoding: Deux et Machina. Newsletter of the Biological Survey of Canada (Terrestrial Arthropods), Opinion Page 22(1). http://www.biology.ualberta.ca/bsc/news22_2/opinionpage.htm.
- Tautz, D., P. Arctander, A. Minelli, R. H. Thomas, and A. P. Vogler. 2002. DNA points the way ahead in taxonomy. *Nature* 418:479.
- Tautz, D., P. Arctander, A. Minelli, R. H. Thomas, and A. P. Vogler. 2003. A plea for DNA taxonomy. *Trends Ecol. Evol.* 18:71–74.
- Thalman, O., J. Hebler, H. N. Poinar, S. Paabo, and L. Vigilant. 2004. Unreliable mtDNA data due to nuclear insertions: A cautionary tale from analysis of humans and other great apes. *Mol. Ecol.* 13:321–335.
- Wheeler, Q. D., and R. Meier. 2000. Species concepts and phylogenetic theory: A debate. Columbia University Press, New York.
- Whitfield, J. 2003. DNA barcodes catalogue animals. *News@Nature.com*. Published online only at: <http://www.nature.com/news/2003/030512-7.html>.
- Will, K. W., and D. Rubinoff. 2004. Myth of the molecule: DNA barcodes for species cannot replace morphology for identification and classification. *Cladistics* 20:47–55.
- Wilson, R. A. 1999. *Species: New interdisciplinary essays*. MIT Press, Cambridge, Massachusetts.

First submitted 23 March 2005; reviews returned 9 June 2005;
final acceptance 12 July 2005
Associate Editor: Vincent Savolainen